

SERVICE MANUAL

INFORMATION FOR USING THE DECK PARTS (OVD-5)

Parts on the deck of our product are very similar as shown below.
Make sure to use the parts listed by Parts No. in the service manual for
the repair, because the deck or your important tape will be damaged.

TABLE OF CONTENTS

SPRING, MAIN BRAKE	1
SPRING, TENSION ARM 1	1
PINCH ROLLER BLOCK	1
MODE SWITCH	2
HOLDER, TENSION	2
CAM, MAIN	3
WORM ASS'Y	3
MAIN BRAKE T ASS'Y	4
LEVER, MAIN BRAKE	4
BRACKET, BRAKE	5
ARM IDLER ASS'Y	5
CLUTCH GEAR T ASS'Y	6
CLUTCH GEAR S ASS'Y	6
AHC ASS'Y	6
CAM PINCH ROLLER	7
P5 ARM ASS'Y	7
CATCHER P5 2	8
MAIN CHASSIS ASS'Y	8
ROD, MAIN ASS'Y	9
CAM, P5	10

The following parts can not be distinguished by the external appearance.

- SPRING, MAIN BRAKE and SPRING, MAIN BRAKE (VP)
- SPRING, TENSION ARM 1 and SPRING, TENSION ARM (1S)
- PINCH ROLLER BLOCK and PINCH ROLLER (PB) BLOCK

So before repairing, please identify each part by referring to the Parts List and Parts No. of Service Manual.

NAME: MODE SWITCH
PART NO.: 0520244003 or 0520244006

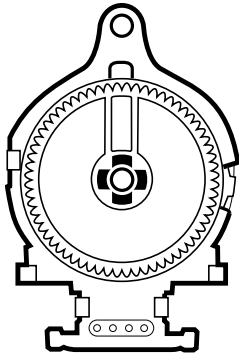

NAME: MODE SWITCH
PART NO.: 0520244005 or 0520244007

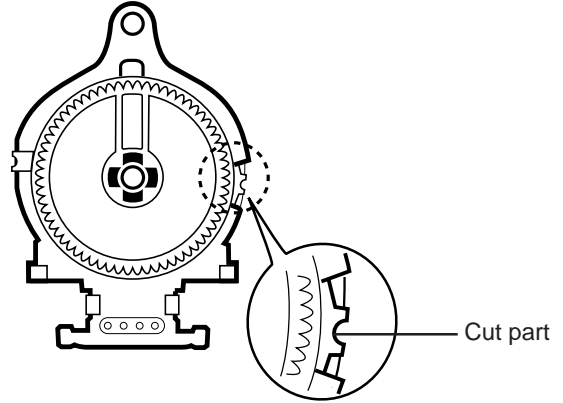

Distinction: You can distinguish by the cut part.

NAME: HOLDER, TENSION
PART NO.: 85OP400359

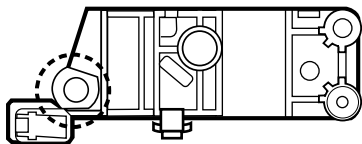

NAME: HOLDER, TENSION (S)
PART NO.: 85OP400452

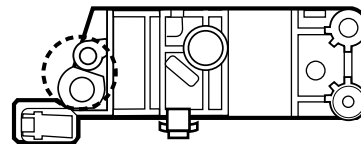

Distinction: You can distinguish by the shape in the dotted circle.

NAME: CAM, MAIN
PART NO.: 85OP600535

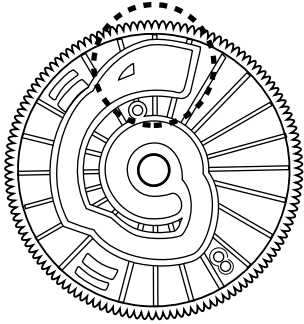

NAME: CAM, MAIN (VP)
PART NO.: 85OP600529

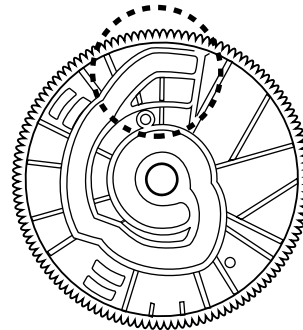

Distinction: You can distinguish by the shape in the dotted circle.

NAME: WORM ASS'Y
PART NO.: 85OA600159

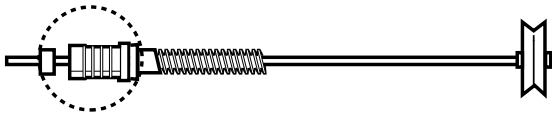

NAME: WORM (VP) ASS'Y
PART NO.: 85OA600179

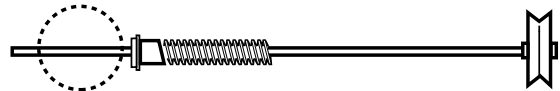

Distinction: You can distinguish by the shape in the dotted circle.

NAME: MAIN BRAKE T ASS'Y
PART NO.: 85OA600156

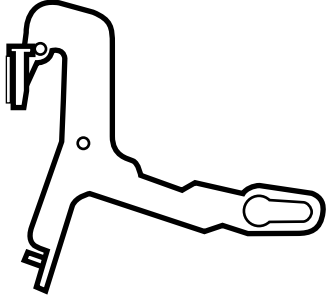

NAME: MAIN BRAKE T (VP) ASS'Y
PART NO.: 85OA600178

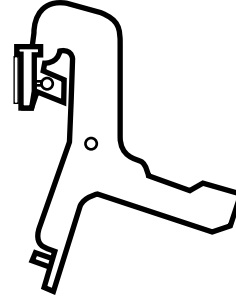

Distinction: You can distinguish by the shape.

NAME: LEVER, MAIN BRAKE
PART NO.: 85OP600468

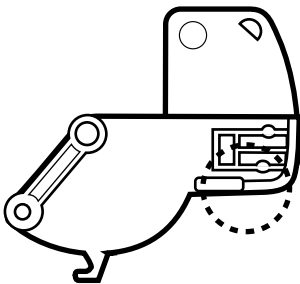

NAME: LEVER, MAIN BRAKE (VP)
PART NO.: 85OP600530

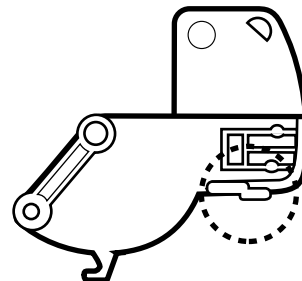

Distinction: You can distinguish by the shape in the dotted circle.

NAME: BRACKET, BRAKE
PART NO.: 85OP600471

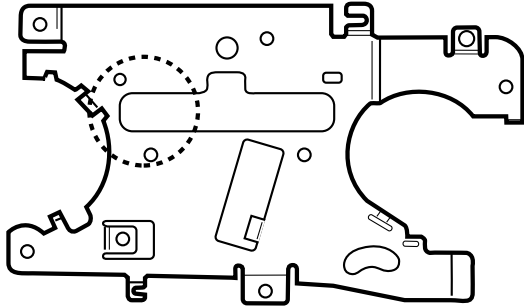

NAME: BRACKET, BRAKE (VP)
PART NO.: 85OP600531

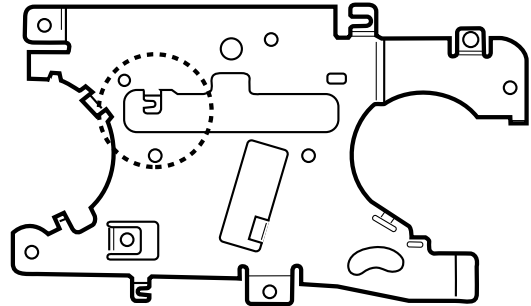

Distinction: You can distinguish by the shape in the dotted circle.

NAME: ARM IDLER ASS'Y
PART NO.: 85OA200065

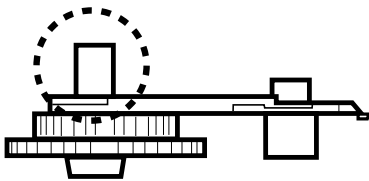

NAME: ARM IDLER (VP) ASS'Y
PART NO.: 85OA200067

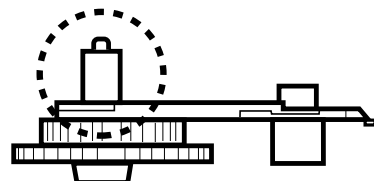

Distinction: You can distinguish by the shape in the dotted circle.

NAME: CLUTCH GEAR T ASS'Y
 PART NO.: 85OA200064
 NAME: CLUTCH GEAR S ASS'Y
 PART NO.: 85OA200063
 NAME: CLUTCH GEAR S (S) ASS'Y
 PART NO.: 85OA200070

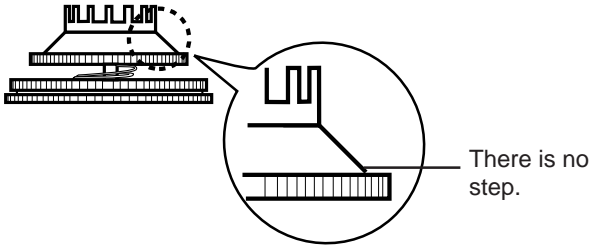

NAME: CLUTCH GEAR T (VP) ASS'Y
 PART NO.: 85OA200069
 NAME: CLUTCH GEAR S (VP) ASS'Y
 PART NO.: 85OA200068
 NAME: CLUTCH GEAR S (VPS) ASS'Y
 PART NO.: 85OA200071

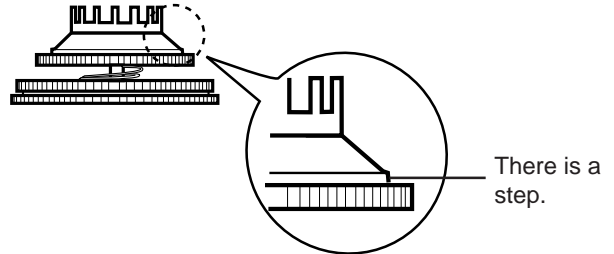

Distinction: You can distinguish by the existence of the step.

NOTE: The following parts can't be distinguished by the external appearance.

- CLUTCH GEAR S ASS'Y and CLUTCH GEAR S (S) ASS'Y
- CLUTCH GEAR S (VP) ASS'Y and CLUTCH GEAR S (VPS) ASS'Y

So before repairing, please identify each parts by referring to the Parts List and Parts No. of Service Manual.

NAME: AHC ASS'Y
 PART NO.: 85OA500013
 MATERIAL COLOR: WHITE

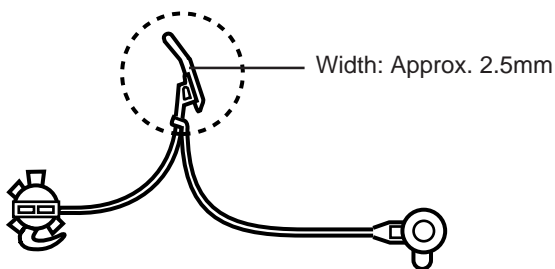

NAME: AHC ASS'Y (2)
 PART NO.: 85OA500020
 MATERIAL COLOR: GRAY

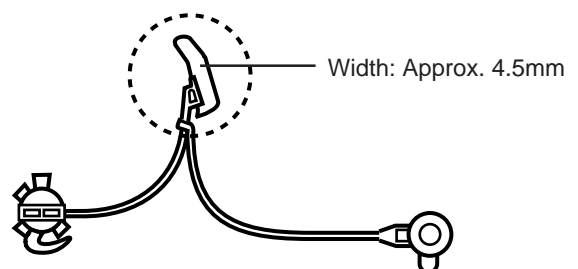

Distinction: You can distinguish by the material color and shape in the dotted circle.

NAME: CAM PINCH ROLLER
PART NO.: 85OP400433
MATERIAL COLOR: WHITE

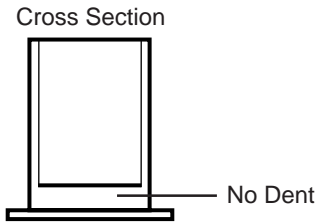

NAME: CAM PINCH ROLLER (PB)
PART NO.: 85OP400430
MATERIAL COLOR: GRAY

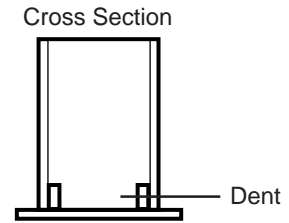

Distinction: You can distinguish by the material color and the dent.

NAME: P5 ARM ASS'Y
PART NO.: 85OA400120



NAME: P5 ARM ASS'Y (PB)
PART NO.: 85OA400168

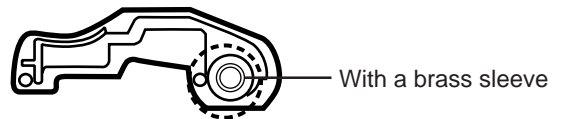

Distinction: You can distinguish by the shape in the dotted circle.

NAME: CATCHER P5 2
PART NO.: 85OP400402

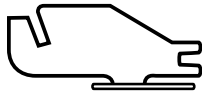

NAME: CATCHER P5 (VP)
PART NO.: 85OP400446

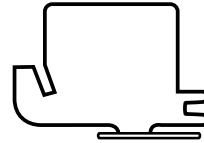

Distinction: You can distinguish by the shape.

NAME: MAIN CHASSIS ASS'Y
PART NO.: 85OA000173, 85OA000221, 85OA000222,
85OA000229 or 85OA000231

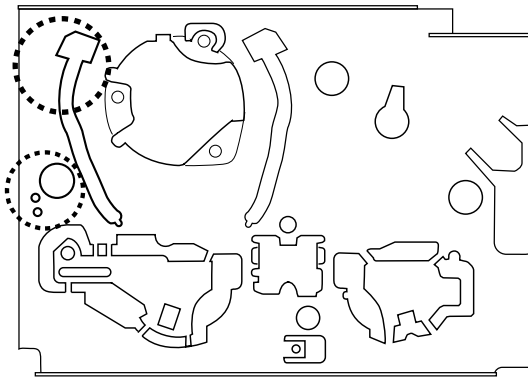

NAME: MAIN CHASSIS ASS'Y
PART NO.: 85OA000227, 85OA000226 or 85OA000230

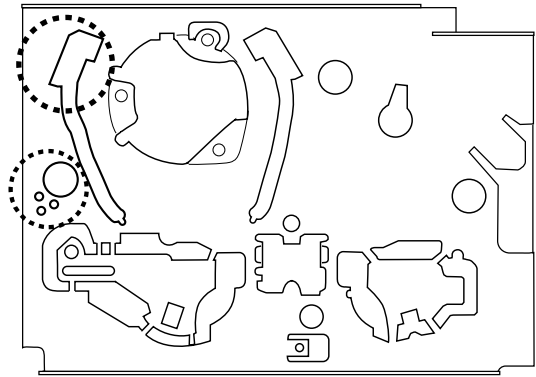

Distinction: You can distinguish by the shape in the dotted circle.

NAME: ROD, MAIN ASS'Y
PART NO.: 85OA600176

RATCHET PLATE (Back Side)

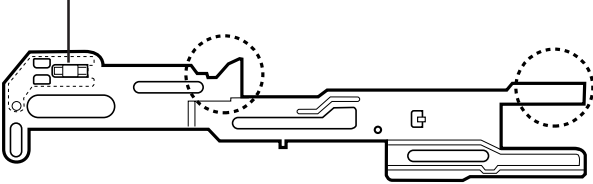

NAME: ROD, MAIN (S)
PART NO.: 85OA600181

RATCHET PLATE (Back Side)

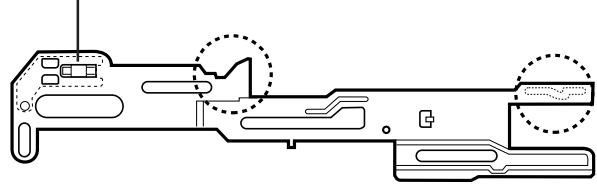

NAME: ROD, MAIN (VP)
PART NO.: 85OP600527

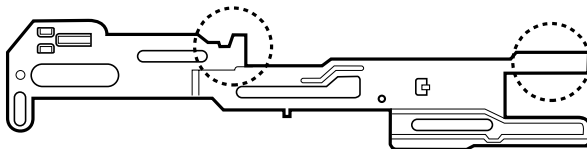

NAME: ROD, MAIN (VPS)
PART NO.: 85OP600538

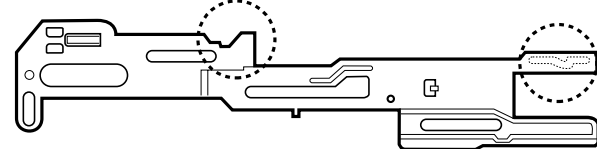

Distinction: You can distinguish by the shape in the dotted circle.

NAME: CAM, P5
PART NO.: 85OP400344

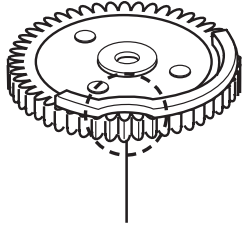

All teeth are the same height.

NAME: CAM, P5
PART NO.: 85OP400450

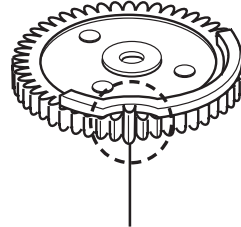

Only one tooth is high.

Distinction: You can distinguish by the tooth height of circled section.

Memorex®

MVT2138

SERVICE MANUAL

COLOR TELEVISION/VIDEO CASSETTE RECORDER

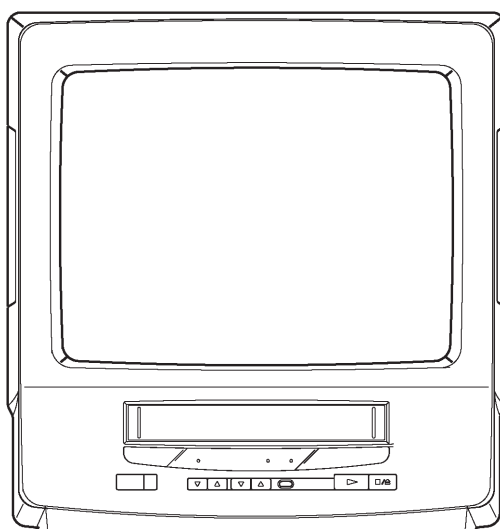

VHS

**ORIGINAL
MFR'S VERSION C**

SERVICING NOTICES ON CHECKING

1. KEEP THE NOTICES

As for the places which need special attentions, they are indicated with the labels or seals on the cabinet, chassis and parts. Make sure to keep the indications and notices in the operation manual.

2. AVOID AN ELECTRIC SHOCK

There is a high voltage part inside. Avoid an electric shock while the electric current is flowing.

3. USE THE DESIGNATED PARTS

The parts in this equipment have the specific characters of incombustibility and withstand voltage for safety. Therefore, the part which is replaced should be used the part which has the same character.

Especially as to the important parts for safety which is indicated in the circuit diagram or the table of parts as a  mark, the designated parts must be used.

4. PUT PARTS AND WIRES IN THE ORIGINAL POSITION AFTER ASSEMBLING OR WIRING

There are parts which use the insulation material such as a tube or tape for safety, or which are assembled in the condition that these do not contact with the printed board. The inside wiring is designed not to get closer to the pyrogenic parts and high voltage parts. Therefore, put these parts in the original positions.

5. TAKE CARE TO DEAL WITH THE CATHODE-RAY TUBE

In the condition that an explosion-proof cathode-ray tube is set in this equipment, safety is secured against implosion. However, when removing it or serving from backward, it is dangerous to give a shock. Take enough care to deal with it.

6. AVOID AN X-RAY

Safety is secured against an X-ray by considering about the cathode-ray tube and the high voltage peripheral circuit, etc.

Therefore, when repairing the high voltage peripheral circuit, use the designated parts and make sure not modify the circuit.

Repairing except indicates causes rising of high voltage, and it emits an X-ray from the cathode-ray tube.

7. PERFORM A SAFETY CHECK AFTER SERVICING

Confirm that the screws, parts and wiring which were removed in order to service are put in the original positions, or whether there are the portions which are deteriorated around the serviced places serviced or not. Check the insulation between the antenna terminal or external metal and the AC cord plug blades. And be sure the safety of that.

(INSULATION CHECK PROCEDURE)

1. Unplug the plug from the AC outlet.
2. Remove the antenna terminal on TV and turn on the TV.
3. Insulation resistance between the cord plug terminals and the external exposure metal **[Note 2]** should be more than 1M ohm by using the 500V insulation resistance meter **[Note 1]**.
4. If the insulation resistance is less than 1M ohm, the inspection repair should be required.

[Note 1]

If you have not the 500V insulation resistance meter, use a Tester.

[Note 2]

External exposure metal: Antenna terminal
Earphone jack

HOW TO ORDER PARTS

Please include the following informations when you order parts. (Particularly the VERSION LETTER.)

1. MODEL NUMBER and VERSION LETTER

The MODEL NUMBER can be found on the back of each product and the VERSION LETTER can be found at the end of the SERIAL NUMBER.

2. PART NO. and DESCRIPTION

You can find it in your SERVICE MANUAL.

CONTENTS

SERVICING NOTICES ON CHECKING	A1-1
HOW TO ORDER PARTS	A1-1
CONTENTS	A2-1
GENERAL SPECIFICATIONS	A3-1~A3-6
DISASSEMBLY INSTRUCTIONS	
1. REMOVAL OF MECHANICAL PARTS AND P.C. BOARDS	B1-1, B1-2
2. REMOVAL OF DECK PARTS	B2-1~B2-5
3. REMOVAL OF ANODE CAP	B3-1
KEY TO ABBREVIATIONS	C1-1, C1-2
PREVENTIVE CHECKS AND SERVICE INTERVALS	C2-1
NOTE FOR THE REPLACING OF MEMORY IC	C3-1
DECK PARTS LOCATIONS	C4-1, C4-2
SERVICING FIXTURES AND TOOLS	C5-1
PREPARATION FOR SERVICING	C5-1
MECHANICAL ADJUSTMENTS	D1-1~D1-3
ELECTRICAL ADJUSTMENTS	D2-1~D3-1
MAJOR COMPONENTS LOCATION GUIDE	D4-1, D4-2
BLOCK DIAGRAMS	
TV BLOCK DIAGRAM	E-1, E-2
Y/C/AUDIO/HEAD AMP	E-3, E-4
SYSTEM CONTROL/SERVO	E-5, E-6
IN/OUT	E-7, E-8
PRINTED CIRCUIT BOARDS	
MAIN/CRT	F-1, F-2
SYSCON	F-3~F-6
OPERATION	F-7, F-8
SCHEMATIC DIAGRAMS	
TIMER MICON	G-1, G-2
IF/CHROMA	G-3, G-4
SOUND AMP	G-5, G-6
DEFLECTION	G-7, G-8
CRT	G-9, G-10
POWER (TV)	G-11, G-12
OPERATION(2)	G-13, G-14
Y/C/AUDIO	G-15, G-16
HEAD AMP	G-17, G-18
IN/OUT	G-19, G-20
SYSTEM CONTROL/SERVO	G-21, G-22
POWER (VCR)	G-23, G-24
OPERATION(1)	G-25, G-26
INTERCONNECTION DIAGRAM	G-27, G-28
WAVEFORMS	H-1~H-4
MECHANICAL EXPLODED VIEWS	I-1, I-2
CHASSIS EXPLODED VIEW	I-3, I-4
FRONT LOADING UNIT 15 EXPLODED VIEW	I-5
MECHANICAL REPLACEMENT PARTS LIST	J1-1
CHASSIS/FRONT LOADING UNIT 15 REPLACEMENT PARTS LIST	J2-1
ELECTRICAL REPLACEMENT PARTS LIST	J3-1~J3-3

GENERAL SPECIFICATIONS

G-1.Outline of the Product

13 inch(335.4mmV):Measured diagonally
 Color CRT 90 degree deflection
3-Speed 1/2" Video Cassette Recorder
VHS Recorder/Player
VHS-C Player

G-2.VCR Format

VHS Standard NTSC PAL SECAM PAL-M PAL-N
VHS Hi-Fi Audio System

G-3.Video Recording System

:Rotary,slant azimuth two head helical scan system

Luminance Component

:FM recording

Chrominance Component

:Low frequency converted direct recording

G-4.Broadcasting System

US System M

G-5.Color System

NTSC PAL SECAM or Monochrome signal

G-6.NTSC Playback(PAL 60Hz)

Yes No

G-7.MESECAM

Yes No

G-8.Cassette Tape

VHS type video cassette tape Width 12.65mm (1/2 Inch)
VHS-C type video cassette tape Width 12.65mm (1/2 Inch)

G-9.Tape Speed

NTSC or PAL-M		PAL or SECAM	
<input checked="" type="checkbox"/> SP	33.35 mm/sec	<input type="checkbox"/> SP	23.39 mm/sec
<input checked="" type="checkbox"/> LP	16.67 mm/sec	<input type="checkbox"/> LP	11.69 mm/sec
<input checked="" type="checkbox"/> SLP	11.12 mm/sec		

G-10.Recording/Playback Time

NTSC or PAL-M
at SP Mode Max. 210 min. (with T-210 cassette)
at LP Mode Max. 420 min. (with T-210 cassette)
at SLP Mode Max. 630 min. (with T-210 cassette)
 PAL or SECAM
at SP Mode Max. 300 min. (with E-300 cassette)
at LP Mode Max. 600 min. (with E-300 cassette)

G-11.Rewind/Fast Forward Time(Approx.)

2' 30" (with E-180 cassette)

G-12.Search Speed

SP 3 and 5 Times
LP 7 and 9 Times
SLP 9 and 15 Times

G-13.Slow Speed

SP _____ Times
LP _____ Times
SLP _____ Times

G-14.Frame Advance

SP _____ Times
LP _____ Times
SLP _____ Times

GENERAL SPECIFICATIONS

G-15. Antenna Input Impedance

VHF/UHF 75 ohm unbalanced

G-16. Tuner and Receiving channel

1 Tuner System

2 Tuner System

Tuner : Contactless Electric tuner

Oscar(W/O HYPER)

Oscar(W/ HYPER)

France CATV

Others

Receiving channel

VHF (LOW) 2 ch~ 6 ch

(HIGH) 7 ch~ 13 ch

(CATV) A5 ch~ I ch

J ch~ W+29 ch

GGG ch~ W+84 ch

UHF 14 ch~ 69 ch

Tuning System

Frequency syn.

Voltage syn.

Others

G-17. Preset Channel

-- channels

G-18. Intermediate Frequency

Picture(FP) 45.75 MHz --- MHz --- MHz

Sound (FS) 41.25 MHz --- MHz --- MHz

FP-FS 4.50 MHz --- MHz --- MHz

G-19. Stereo/Dual TV Sound

Yes(NICAM

GERMAN

USA

JAPAN)

No

G-20. Video Signal

Input Level 1 Vp-p / 75 ohm

Output Level 1 Vp-p / 75 ohm

S/N Ratio 50 dB (Weighted)

Horizontal Resolution at SP Mode 230 Lines

G-21. Audio Signal

Input Level

Line -- dB / -- Kohm

RCA - 8 dB / 50 Kohm

Output Level

Line -- dB / -- Kohm

RCA - 6 dB / 1 Kohm

(0dB=0.775 V rms)

S/N Ratio at SP Mode 42 dB

Harmonic Distortion : 1.5 % (1KHz)

Frequency Response : at SP Mode 120 Hz ~ 10 KHz

at LP Mode 120 Hz ~ 6 KHz

at SLP Mode 120 Hz ~ 4 KHz

G-22. Heads

Video 2 Rotary Heads

FM Audio --- Rotary Heads

Audio / Control 1 Stationary Head (Mono Stereo(L,R))

Erase 1 Full Track Erase

G-23. Motor: 3 Motors

Tape/Cassette Loading

Cylinder (Direct Drive)

Capstan (Direct Drive)

G-24. Power Source

120 V

AC 50Hz

AC 60Hz

EXT DC Jack 12 V

GENERAL SPECIFICATIONS

G-25. Power Consumption: $\frac{88}{54}$ W at AC $\frac{120}{12}$ V $\frac{60}{}$ Hz
 (at TV and VCR ON)
 Stand by: $\frac{10}{}$ W at AC $\frac{120}{}$ V $\frac{60}{}$ Hz
 Per Year: $\frac{--}{}$ kWh / Year

G-26. Dimensions (Approx.)
365 mm(W) 370 mm(D) 382 mm(H)

G-27. Weight (Approx.) Net : 12.5 Kg (27.6 lbs)
 Gross: 14.5 Kg (32.2 lbs)

G-28. Cabinet Material

Cabinet Front:	<input checked="" type="checkbox"/> PS <input type="checkbox"/> ABS	<input type="checkbox"/> 94HB <input type="checkbox"/> 94V2 <input checked="" type="checkbox"/> 94V0	<input checked="" type="checkbox"/> DECABROM <input type="checkbox"/> NON-DECA
Cabinet Rear:	<input type="checkbox"/> PS <input checked="" type="checkbox"/> ABS	<input type="checkbox"/> 94HB <input type="checkbox"/> 94V2 <input checked="" type="checkbox"/> 94V0	<input type="checkbox"/> DECABROM <input checked="" type="checkbox"/> NON-DECA
Jack Panel:	<input checked="" type="checkbox"/> PS <input type="checkbox"/> ABS	<input type="checkbox"/> 94HB <input type="checkbox"/> 94V2 <input checked="" type="checkbox"/> 94V0	<input checked="" type="checkbox"/> DECABROM <input type="checkbox"/> NON-DECA

G-29. Cassette Loading System: Front Cassette Loading System
 Top Loading System

G-30. Tape Counter: Linear Time Tape Counter

G-31. Protector: Power Fuse Dew Sensor

G-32. Regulation

Safety

<input checked="" type="checkbox"/> UL	<input checked="" type="checkbox"/> CSA	<input type="checkbox"/> SAA	<input type="checkbox"/> SI	<input type="checkbox"/> CE	<input type="checkbox"/> SEV
<input type="checkbox"/> BS	<input type="checkbox"/> NF	<input type="checkbox"/> NEMKO	<input type="checkbox"/> FEMKO	<input type="checkbox"/> DEMKO	<input type="checkbox"/> IEC65
<input type="checkbox"/> SEMKO	<input type="checkbox"/> NZ	<input type="checkbox"/> HOMOLO	<input type="checkbox"/> SABS	<input type="checkbox"/> CNS	<input type="checkbox"/> SISIR
<input type="checkbox"/> NOM	<input type="checkbox"/> AS3159	<input type="checkbox"/> DENTORI	<input type="checkbox"/> UNE	<input type="checkbox"/> GOST	<input type="checkbox"/> NONE

Radiation

<input checked="" type="checkbox"/> FCC	<input checked="" type="checkbox"/> DOC	<input type="checkbox"/> FTZ	<input type="checkbox"/> PTT	<input type="checkbox"/> CE	<input type="checkbox"/> SEV
<input type="checkbox"/> SABA	<input type="checkbox"/> SI	<input type="checkbox"/> NF	<input type="checkbox"/> NZ	<input type="checkbox"/> HOMOLO	<input type="checkbox"/> UNE
<input type="checkbox"/> CNS	<input type="checkbox"/> CISPR13	<input type="checkbox"/> DENTORI	<input type="checkbox"/> AS/NZS	<input type="checkbox"/> NONE	

X-Radiation

<input type="checkbox"/> PTB	<input checked="" type="checkbox"/> DHHS	<input checked="" type="checkbox"/> HWC	<input type="checkbox"/> DENTORI	<input type="checkbox"/> NONE
------------------------------	--	---	----------------------------------	-------------------------------

G-33. Temperature

Operation 5 °C ~ 40 °C

Storage -20 °C ~ 60 °C

G-34. Operating Humidity Less than 80 %RH

G-35. Clock and Timer

Built-in 1 Month 7 Events Programmable Timer

One Touch Recording : Max Time 5 Hours

Sleep Timer Yes Max 120 Min. (10 Min. Step) No

On/Off Timer Yes _____ Programs No

Wake Up Timer Yes _____ Programs No

G-36. Timer back up Time

More than 1/12 Minutes (at Power Off Mode)

GENERAL SPECIFICATIONS

G-37.Terminals

- | | | | |
|--|--|--|--------------------------------------|
| <input checked="" type="checkbox"/> VHF/UHF Antenna | <input type="checkbox"/> Din Type | <input checked="" type="checkbox"/> F-Type | <input type="checkbox"/> France Type |
| <input type="checkbox"/> Video Input(Front) | <input type="checkbox"/> Phono Jack (RCA ø8.3) | <input type="checkbox"/> BNC | |
| <input checked="" type="checkbox"/> Video Input(Rear) | <input checked="" type="checkbox"/> Phono Jack (RCA ø8.3) | <input type="checkbox"/> BNC | |
| <input checked="" type="checkbox"/> Video Output(Rear) | <input checked="" type="checkbox"/> Phono Jack (RCA ø8.3) | <input type="checkbox"/> BNC | |
| <input type="checkbox"/> Audio Input(Front) | <input type="checkbox"/> Phono Jack (RCA ø8.3) | | |
| <input checked="" type="checkbox"/> Audio Input(Rear) | <input checked="" type="checkbox"/> Phono Jack (RCA ø8.3) | | |
| <input checked="" type="checkbox"/> Audio Output(Rear) | <input checked="" type="checkbox"/> Phono Jack (RCA ø8.3) | | |
| <input type="checkbox"/> 21 Pin | <input checked="" type="checkbox"/> DC Jack 12V (Center +) | | |
| <input type="checkbox"/> AC Inlet | <input type="checkbox"/> Ext Speaker | | |
| <input type="checkbox"/> Diversity | <input checked="" type="checkbox"/> Ear Phone | | |
| <input type="checkbox"/> Head Phone | | | |

G-38.Indicator

- | | | | | |
|--|---|--|--------------------------------------|---|
| <input checked="" type="checkbox"/> Power (Red) | <input checked="" type="checkbox"/> Rec/OTR (Red) | <input checked="" type="checkbox"/> Play (Red) | <input type="checkbox"/> Tape-In () | <input checked="" type="checkbox"/> Timer Rec (Red) |
| <input type="checkbox"/> Stand By () | <input type="checkbox"/> On Timer () | <input type="checkbox"/> Rental Mode(or Clear Picture) () | | |
| <input type="checkbox"/> One Touch Playback(Button Lights) | <input type="checkbox"/> Charge () | | | |
| <input checked="" type="checkbox"/> Dew Sensor(Play LED Flush) | <input type="checkbox"/> NONE | | | |

G-39.On Screen Display

- Menu
 - Clock Set(Calendar 12H 24H)
 - Timer Rec Set
 - Auto Repeat On/Off
 - On/Off Timer Set
 - Guide CH Set
 - ATS
 - Protect On/Off
 - Language
 - Area Code
 - Channel Set
 - Picture
 - System Select
 - User Registration
- G-CODE(or SHOWVIEW or PLUSCODE)No. Entry
- Clock
- Tape Counter/Memory
- Sleep Time
- Control Level (Vol,Bright,Cont,Color,Tint,Sharpness)
- Control Level (Vol,Bright,Cont,Color,Sharpness)
- Play/Stop/FF/Rew/Rec/OTR/T-Rec/Pause
- Auto Tracking/Manual Tracking
- Index
- Add/Delete
- Wide Select
- Tone 1/2
- CH
- Tape Speed
- EXT.Input
- Caption 1/2
- Sound Mute
- Auto Wide On/Off
- Picture Position
- Stereo

G-40.OSD Language

- Eng Ger Fre Spa Ita Por Jan

OSD Language Setting

- Eng Ger Fre Spa Ita Por Jan
 Not Applicable

G-41.Speaker

- Position Front Side Bottom
 Size 3 inches
 Imp 8 ohm x 1 pcs
 Power Max 1.0 W (Typical)
 10% 0.7 W (Typical)

GENERAL SPECIFICATIONS

G-42.EXT Speaker : Yes -- W Imp -- ohm

G-43.Carton

Master Carton: Need No Need
 Content: ---- Set
 Material: ---- / ---- Corrugated Carton
 Dimensions: ---- mm(W) ---- mm(D) ---- mm(H)
 Description of Origin Yes No

Gift Box

Material AB Double/Brown Corrugated Carton (with Photo Label)
 AB Double/White Corrugated Carton (with Photo Label)
 AB Double Full Color Carton W/Photo

Dimensions: 447 mm(W) 423 mm(D) 443 mm(H)

Design: As Per BUYER's

Description of Origin: Yes No

Drop Test Natural Dropping At 1 Corner / 3 Edges / 6 Surfaces

Height 25cm 31cm 46cm 62cm 80cm

Container Stuffing: 700 Sets / 40' container

G-44.Accessories

<input type="checkbox"/> Channel Film	<input type="checkbox"/> Dew Caution Sheet
<input checked="" type="checkbox"/> Owner's Manual (<input type="checkbox"/> W/Guarantee Card) [English/French]	
<input checked="" type="checkbox"/> Remote Control Unit	<input type="checkbox"/> AC Plug Adaptor
<input checked="" type="checkbox"/> Rod Antenna (<input type="checkbox"/> One Pole <input checked="" type="checkbox"/> Two Pole/ <input checked="" type="checkbox"/> F-Type <input type="checkbox"/> DIN Type <input type="checkbox"/> France Type)	
<input type="checkbox"/> Loop Antenna(<input type="checkbox"/> F-Type <input type="checkbox"/> DIN Type <input type="checkbox"/> France Type)	
<input type="checkbox"/> U/V Mixer	<input type="checkbox"/> Quick Set-up Sheet
<input checked="" type="checkbox"/> DC Car Cord (Center+)	<input type="checkbox"/> Battery (UM- <u>4 x 2</u>)
<input checked="" type="checkbox"/> Guarantee Card <input type="checkbox"/> AC Cord	
<input type="checkbox"/> Warning Sheet <input type="checkbox"/> AV Cord (2Pin-1Pin)	
<input type="checkbox"/> Circuit Diagram	<input type="checkbox"/> Registration Card
<input type="checkbox"/> Antenna Change Plug	<input type="checkbox"/> PTB Sheet
<input type="checkbox"/> Service Facility List	<input type="checkbox"/> 300 ohm to 75 ohm Antenna Plug
	<input type="checkbox"/> Euro Warranty Information Sheet

G-45.Other Features

<input checked="" type="checkbox"/> Auto Head Cleaning	<input type="checkbox"/> Index Search
<input checked="" type="checkbox"/> Auto Tracking	<input type="checkbox"/> Auto Search
<input type="checkbox"/> CH Auto Set-Up/Auto Clock	<input type="checkbox"/> ATS
<input type="checkbox"/> VIDEO PLUS+(SHOWVIEW,G-CODE)	<input type="checkbox"/> PDC
<input checked="" type="checkbox"/> HQ (VHS Standard High Quality)	<input type="checkbox"/> VPS
<input checked="" type="checkbox"/> Auto Power On, Auto Play, Auto Rewind, Auto Eject,Auto Repeat System	
<input checked="" type="checkbox"/> Forward / Reverse Picture Search	<input type="checkbox"/> SQPB
<input type="checkbox"/> One Touch Playback	<input checked="" type="checkbox"/> CATV(181CH)
<input type="checkbox"/> Auto CH Memory	<input type="checkbox"/> Anti-Theft
<input type="checkbox"/> Just Clock Function	<input type="checkbox"/> Rental Mode
<input checked="" type="checkbox"/> Closed Caption	<input type="checkbox"/> Fastext
<input type="checkbox"/> Toptext	<input type="checkbox"/> Unitext
<input checked="" type="checkbox"/> TV Auto Shutt off Function	<input checked="" type="checkbox"/> TV Monitor
<input type="checkbox"/> NTSC Playback PAL TV (PAL 60Hz)	<input type="checkbox"/> TV/Rec Monitor
<input checked="" type="checkbox"/> One Touch Automatic Channel Programing	

GENERAL SPECIFICATIONS

G-46.Switch

- | | | | |
|-------|--|--|---|
| Front | <input checked="" type="checkbox"/> Power(Tact) | <input checked="" type="checkbox"/> Channel Up | <input checked="" type="checkbox"/> Volume Up |
| | <input checked="" type="checkbox"/> Play | <input checked="" type="checkbox"/> Channel Down | <input checked="" type="checkbox"/> Volume Down |
| | <input type="checkbox"/> Pause/Still | <input type="checkbox"/> F.FWD/Cue | <input type="checkbox"/> Rew/Rev |
| | <input type="checkbox"/> System Select | <input checked="" type="checkbox"/> Eject/Stop | <input checked="" type="checkbox"/> Rec/OTR |
| | <input type="checkbox"/> One Touch Playback | <input type="checkbox"/> Main Power SW | |
| Rear | <input type="checkbox"/> Color On/Off (SECAM only) | <input type="checkbox"/> Degauss | |
| | <input type="checkbox"/> Main Power SW | | <input type="checkbox"/> AC/DC |

G-47.Magnetic Field

- | | | |
|---|--------------------------------------|--------------------------------------|
| <input checked="" type="checkbox"/> BV : +0.45G | <input type="checkbox"/> BV : +0.35G | <input type="checkbox"/> BV : +0.25G |
| BH : 0.18G | BH : 0.30G | BH : 0.30G |
| <input type="checkbox"/> BV : -0.15G | <input type="checkbox"/> BV : -0.25G | <input type="checkbox"/> BV : -0.50G |
| BH : 0.15G | BH : 0.15G | BH : 0.30G |

G-48.Remote Control Unit:

RC-BH

Power Source:

D.C 3 V Battery UM - 4 x 2

- | | | |
|---|--|---|
| <input checked="" type="checkbox"/> 0 | <input checked="" type="checkbox"/> Power | <input checked="" type="checkbox"/> Prog.CFM |
| <input checked="" type="checkbox"/> 1 | <input checked="" type="checkbox"/> Rec/OTR | <input checked="" type="checkbox"/> Enter |
| <input checked="" type="checkbox"/> 2 | <input checked="" type="checkbox"/> Play | <input checked="" type="checkbox"/> Set + |
| <input checked="" type="checkbox"/> 3 | <input checked="" type="checkbox"/> F.Fwd | <input checked="" type="checkbox"/> Set - |
| <input checked="" type="checkbox"/> 4 | <input checked="" type="checkbox"/> Rew | <input type="checkbox"/> Auto Ch Memory |
| <input checked="" type="checkbox"/> 5 | <input checked="" type="checkbox"/> Pause/Still | <input type="checkbox"/> Delete |
| <input checked="" type="checkbox"/> 6 | <input checked="" type="checkbox"/> Stop | <input type="checkbox"/> Add |
| <input checked="" type="checkbox"/> 7 | <input type="checkbox"/> Eject | <input checked="" type="checkbox"/> Tracking Auto |
| <input checked="" type="checkbox"/> 8 | <input type="checkbox"/> Slow | <input checked="" type="checkbox"/> Tracking Up |
| <input checked="" type="checkbox"/> 9 | <input type="checkbox"/> Clock/Counter | <input checked="" type="checkbox"/> Tracking Down |
| <input type="checkbox"/> 10 | <input checked="" type="checkbox"/> Counter Memory | <input checked="" type="checkbox"/> Call |
| <input type="checkbox"/> 11 | <input checked="" type="checkbox"/> Counter Reset | <input checked="" type="checkbox"/> TV/Caption/Text |
| <input type="checkbox"/> 12 | <input type="checkbox"/> TV/VCR | <input type="checkbox"/> Caption On/Off |
| <input checked="" type="checkbox"/> Ch Up | <input checked="" type="checkbox"/> Speed | <input checked="" type="checkbox"/> Ch. 1/2 |
| <input checked="" type="checkbox"/> Ch Down | <input type="checkbox"/> Index | <input type="checkbox"/> Caption 1/2 |
| <input checked="" type="checkbox"/> Volume Up | <input checked="" type="checkbox"/> Sleep Timer | <input checked="" type="checkbox"/> Mute |
| <input checked="" type="checkbox"/> Volume Down | <input type="checkbox"/> Repeat | <input type="checkbox"/> Preset (Ch Set) |
| <input checked="" type="checkbox"/> Quick View | <input type="checkbox"/> Bar Select | <input type="checkbox"/> AFT |
| <input type="checkbox"/> Clock/Prog | <input type="checkbox"/> Normalize | <input type="checkbox"/> Select |
| <input checked="" type="checkbox"/> Menu | <input checked="" type="checkbox"/> Cancel | <input checked="" type="checkbox"/> Timer Rec |
| <input type="checkbox"/> Search Up | <input checked="" type="checkbox"/> TV Monitor | <input type="checkbox"/> Ch.Set |
| <input type="checkbox"/> Search Down | <input type="checkbox"/> Mute/Normal | <input type="checkbox"/> Daily |
| <input type="checkbox"/> Fine Tuning Up/Tracking Up | | <input type="checkbox"/> Rental Mode |
| <input type="checkbox"/> Fine Tuning Down/Tracking Down | | <input type="checkbox"/> Input Select |
| <input type="checkbox"/> Tuning Select (Auto Search On/Off) | | <input type="checkbox"/> Once |
| <input type="checkbox"/> One Touch Playback | <input type="checkbox"/> VIDEO PLUS+ (SHOWVIEW,G-CODE) | |
| <input type="checkbox"/> Weekly | <input type="checkbox"/> F/T/B | <input type="checkbox"/> Text/Mix/TV |
| <input type="checkbox"/> Red | <input type="checkbox"/> Cyan | <input type="checkbox"/> Yellow |
| <input type="checkbox"/> Green | <input type="checkbox"/> Status | <input checked="" type="checkbox"/> Reset |

DISASSEMBLY INSTRUCTIONS

1. REMOVAL OF MECHANICAL PARTS AND P.C. BOARDS

1-1: BACK CABINET (Refer to Fig. 1-1)

1. Remove the 4 screws ①.
2. Remove the 2 screws ②.
3. Remove the screw ③.
4. Remove the Back Cabinet in the direction of arrow.

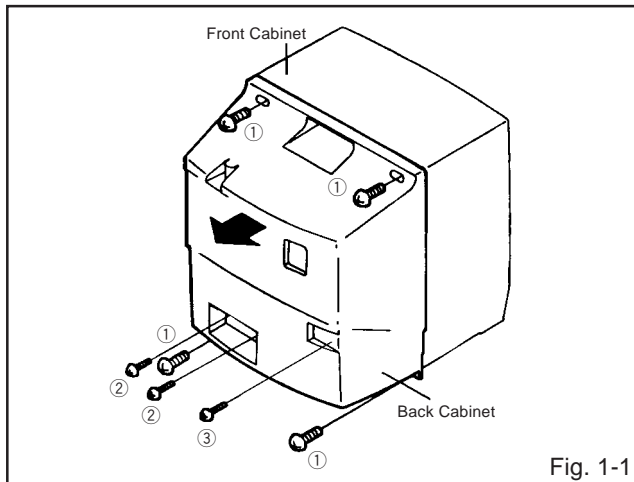

Fig. 1-1

CAUTION: BEFORE REMOVING THE ANODE CAP, DISCHARGE ELECTRICITY BECAUSE IT CONTAINS HIGH VOLTAGE. BEFORE ATTEMPTING TO REMOVE OR REPAIR ANY PCB, UNPLUG THE POWER CORD FROM THE AC SOURCE.

1-2: TV BLOCK (Refer to Fig. 1-2)

1. Remove the CRT PCB in the direction of arrow (A), then unplug the following connector: (CP801).
2. Remove the Anode Cap.
(Refer to REMOVAL OF ANODE CAP)
3. Disconnect the following connectors: (CP820, CP810, CD850, CP401, CD840 and CP502).
4. Slide out the TV Block in the direction of arrow (B).

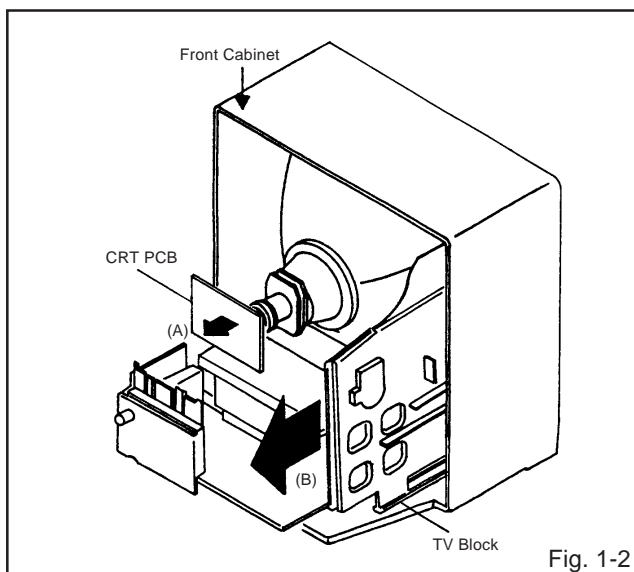

Fig. 1-2

1-3: VCR BLOCK (Refer to Fig. 1-3)

1. Remove the 2 screws ①.
2. Disconnect the following connector: (CP351).
3. Unlock the support ②.
4. Remove the VCR Block in the direction of arrow.

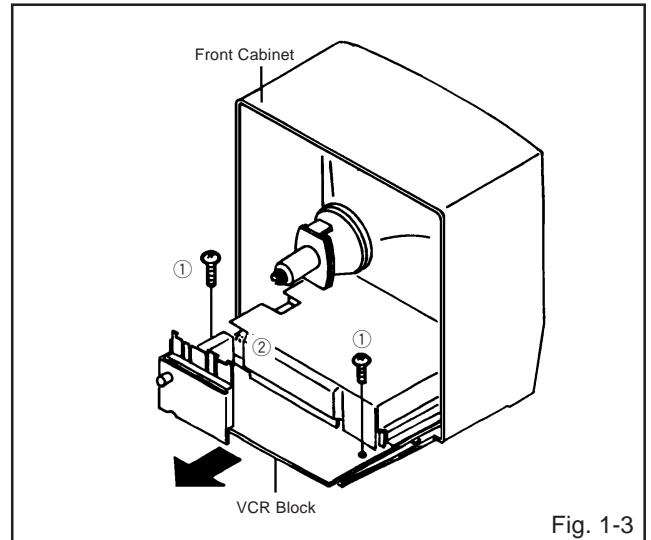

Fig. 1-3

1-4: MAIN PCB (Refer to Fig. 1-4)

1. Remove the 5 screws ①.
2. Remove the screw ②.
3. Unlock the 2 supports ③ and remove the Main PCB in the direction of the arrow.

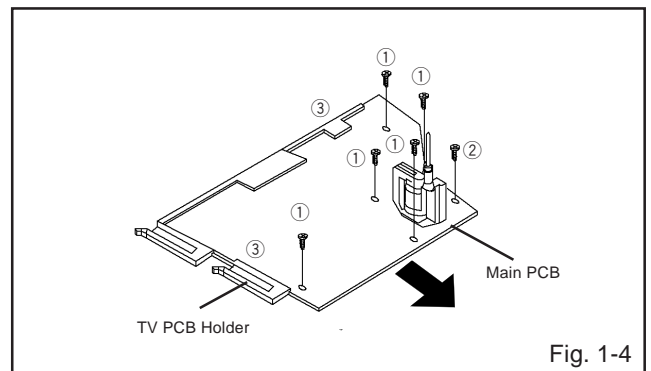

Fig. 1-4

1-5: DECK SHIELD PLATE (Refer to Fig. 1-5)

1. Remove the 4 screws ①.
2. Remove the Deck Shield Plate in the direction of arrow.

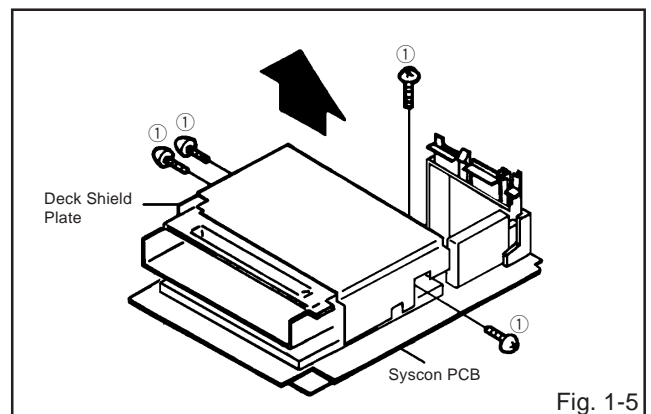
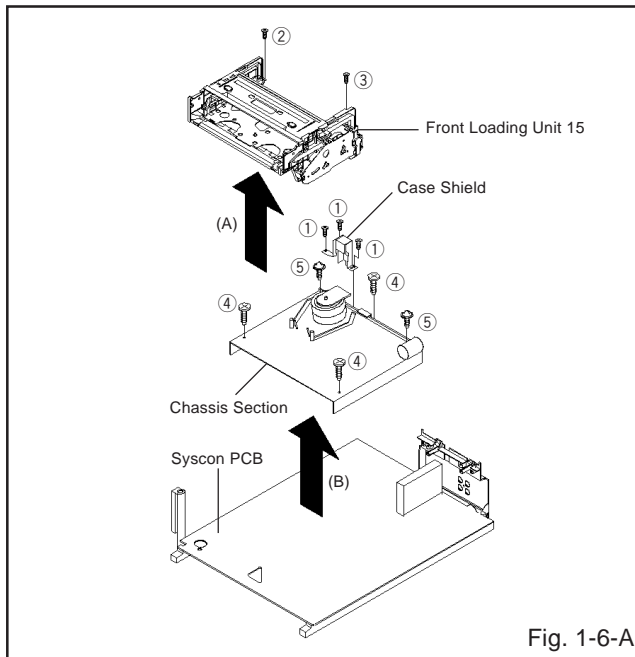

Fig. 1-5

DISASSEMBLY INSTRUCTIONS

1-6: FRONT LOADING UNIT 15, CHASSIS SECTION AND CASE SHIELD (Refer to Fig. 1-6-A)

1. Remove the 3 screws ①.
2. Remove the Case Shield.
3. Remove the screw ②.
4. Remove the screw ③.
5. Remove the Front Loading Unit 15 in the direction of arrow (A).
6. Remove the 3 screws ④.
7. Remove the 2 screws ⑤.
8. Disconnect the following connector: (CP4101 , CD1002, CD4002, CP1004 and CP4106).
9. Remove Chassis Section in the direction of arrow (B).



1-7: JACK PLATE AND SYSCON PCB (Refer to Fig. 1-7)

1. Remove the screw ①.
2. Remove the Syscon PCB in the direction of arrow (A).
3. Remove the screw ②.
4. Remove the Nut ③.
5. Unlock the 2 support ④ and remove the Jack Plate in the direction of arrow (B).

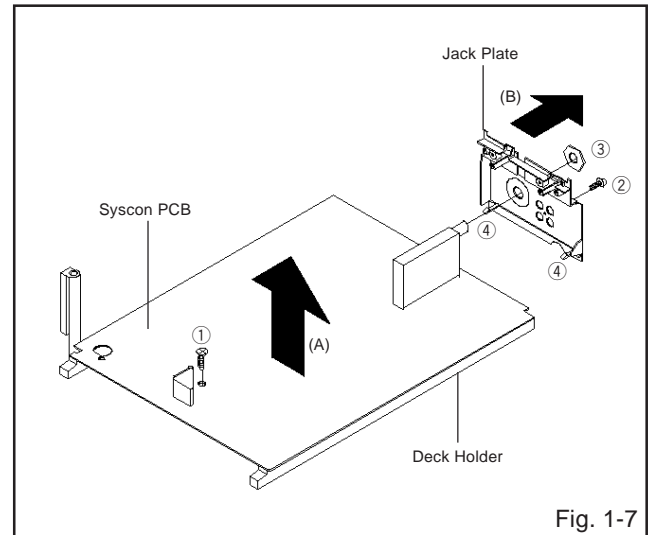

NOTE

When installing the Front Loading Unit 15, align the timing marks and pull the Cassette Holder Ass'y in the direction of arrow (C). (Refer to Fig. 1-6-B)

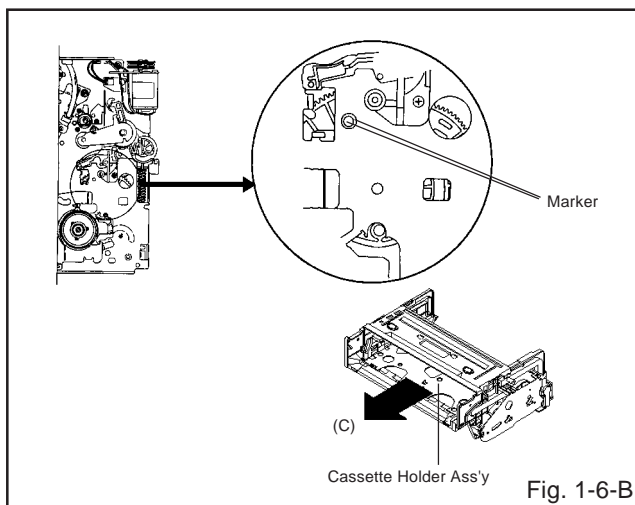

DISASSEMBLY INSTRUCTIONS

2. REMOVAL OF DECK PARTS

2-1: LINK GEAR (R) / CAM GEAR (Refer to Fig. 2-1)

1. Unlock the support ①.
2. Remove the BOT Sensor Cover and BOT Reflector.
3. Unlock the 3 supports ②.
4. Remove the Side Bracket R2 and Spring Earth.
5. Remove the Flap Lever, Link Gear (R) , Cam Gear Ass'y and BOT Lever.

NOTES

1. When installing the BOT Lever, insert the BOSS into the hole of Link Gear (R).
2. When installing the Link Ass'y 3 and Link Gear (R), align the timing Marks.

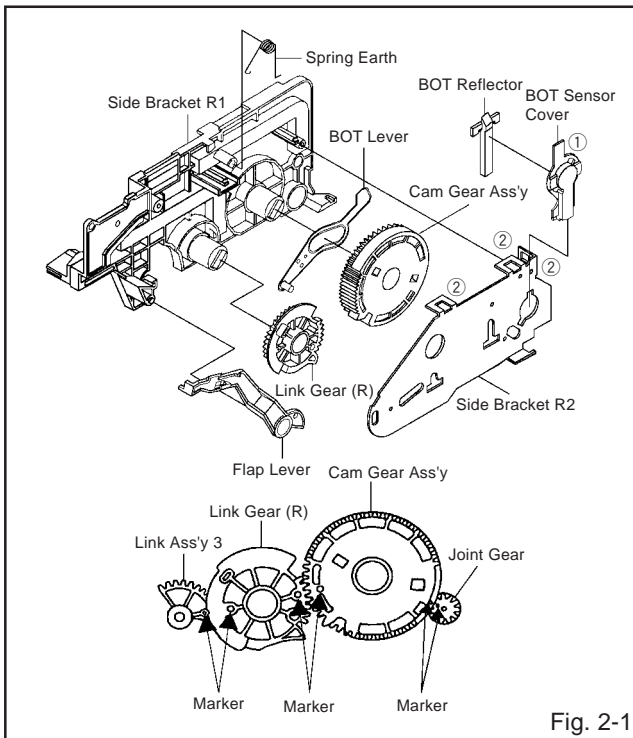

Fig. 2-1

2-2: TOP BRACKET / TAPE PIECE GUIDE (Refer to Fig. 2-2)

1. Remove the Rec Lever Spring.
2. Unlock the 2 supports ①.
3. Remove the Tape Piece Guide.
4. Unlock the 4 supports ②.
5. Remove the Top Bracket.
6. Remove the Side Bracket R1 and Side Bracket L.
7. Unlock the support ③.
8. Remove the Joint Gear.
9. Remove the Bracket R Spring.

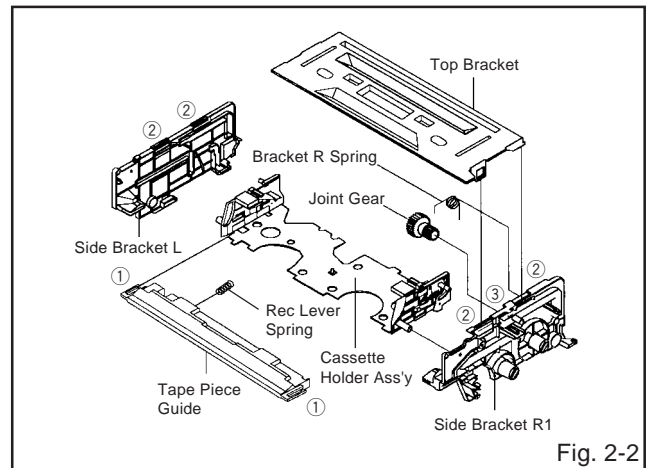

Fig. 2-2

2-3: LINK ASS'Y 3 (Refer to Fig. 2-3)

1. After removing in the direction (A) of Link Ass'y 3, remove the Link Ass'y 3 in the direction (B).

NOTE

Install the (B) first, then install the (A).

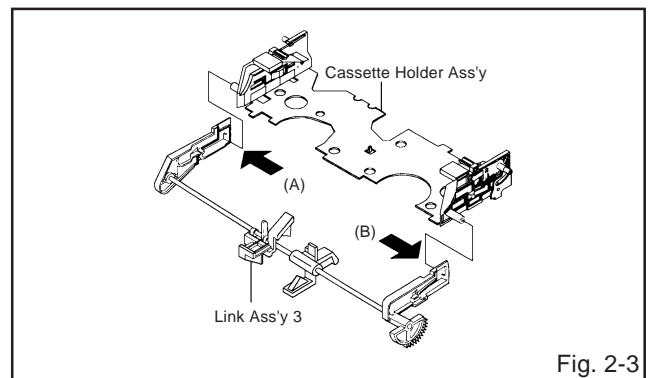

Fig. 2-3

2-4: CASSETTE SIDE R (Refer to Fig. 2-4)

1. Unlock the 2 supports ①.
2. Remove the Cassette Side R.
3. Remove the Pack Spring.
4. Remove the Locker Spring.
5. Unlock support ②.
6. Remove the Locker R.

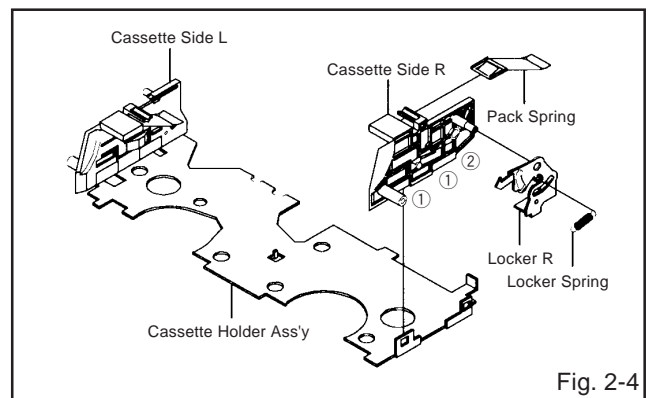

Fig. 2-4

DISASSEMBLY INSTRUCTIONS

2-5: CASSETTE SIDE L (Refer to Fig. 2-5)

1. Unlock the 2 supports ①.
2. Remove the Cassette Side L.
3. Remove the Pack Spring.
4. Remove the Locker Spring.
5. Unlock the support ②.
6. Remove the Locker L.

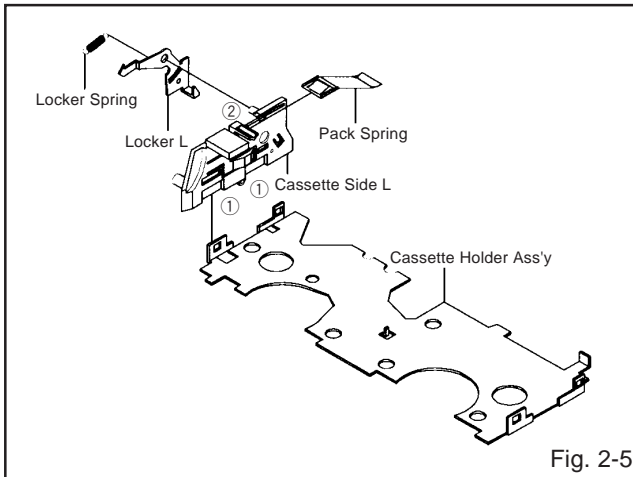

Fig. 2-5

2-6: BRAKE BRACKET (Refer to Fig. 2-6)

1. Remove the Main Brake Spring, S-S Brake Spring, Joint Arm Spring and T-S Brake Spring.
2. Remove the 2 screws ①.
3. Remove the screw ②.
4. Remove the Brake Bracket.
5. Remove the Sub Brake S, Sub Brake T and Main Brake T Ass'y.
6. Remove the Joint Arm.
7. Remove the Reflector LED 2.

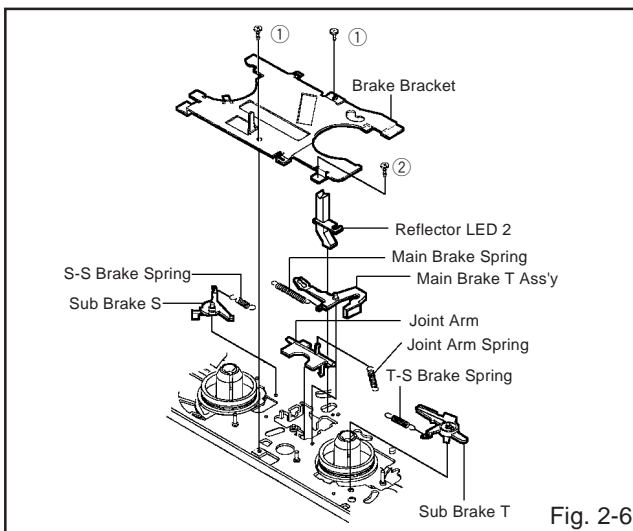

Fig. 2-6

2-7: TENSION BAND (Refer to Fig. 2-7)

1. Remove the Tension Arm Spring 1.
2. Remove the Tension Arm Spring 2.
3. Remove the Tension Adjust.
4. Remove the Tension Arm Ass'y.
5. Remove the Tension Band Ass'y.
6. Remove the Tension Lever 2 Ass'y.

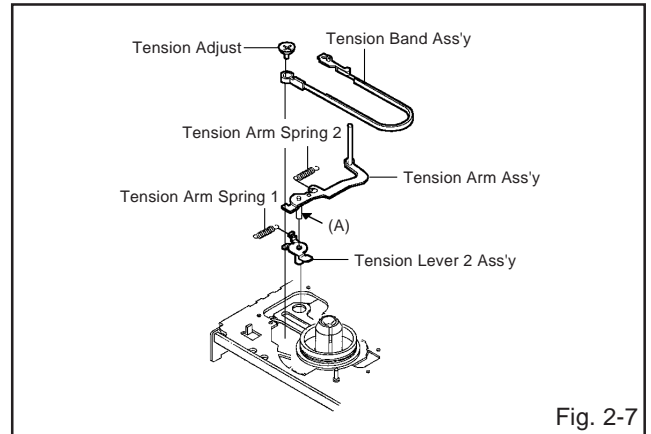

Fig. 2-7

NOTE

1. Install the Tension Band Ass'y without twisting it.
2. Turbine Oil (Lubricating Grade #150) the area marked with A in Fig. 2-7.

EX: KYOUDO Oil Sulaidasu #150
IDEMITSU Oil Super Multi #150

2-8: REEL DISK (Refer to Fig. 2-8)

1. Remove the Reel Disk S and Reel Disk T.
2. Remove the 2 polyslider washers.

NOTES

1. Installation of Reel Disk after performing step 1, 2 and 3 in section 2-7 of DISASSEMBLY INSTRUCTIONS.
 2. The Height Adjustment washers are sometimes attached to the back of the Reel Disk.
 3. Clean the Reel Disk Shaft and put in height adjusting washers.
 4. Be careful not to damage the Tension Band Ass'y at the time of removal and installation.
 5. Be careful not to scratch the Reel Disk Shaft with the polyslider washer or the tool at the time of removal and installation.
 6. After oiling (Lubricating Grade #150) the Reel Disk Shaft, install the new Reel Disk S and Reel Disk T again.
- EX: KYOUDO Oil Sulaidasu #150
IDEMITSU Oil Super Multi #150
7. After installation, adjust the height of the Reel Disk. (Refer to item 1-1 of MECHANICAL ADJUSTMENTS)
 8. After installation, adjust and confirm the tension post position. (Refer to item 1-2 of MECHANICAL ADJUSTMENTS)

DISASSEMBLY INSTRUCTIONS

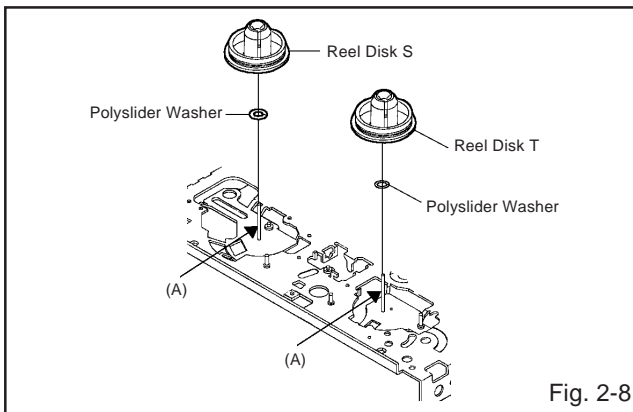

Fig. 2-8

2-9: PINCH ROLLER / CASSETTE OPENER (Refer to Fig. 2-9)

1. Unlock the support ①.
2. Remove the Pinch Roller.
3. Remove the screw ②.
4. Unlock the 2 supports ③.
5. Remove the Cassette Opener.
6. Remove the Spring P5 and Arm P5 Ass'y.
7. Remove the Cam Gear, Polyslider Washer ④, Spring Cam Pinch and Cam Pinch Roller.
8. Remove the Polyslider Washer ⑤ and Cam P5.

NOTES

1. Do not touch the Pinch Roller. (Use gloves.)
2. When installing the Cam P5, Cam Pinch Roller and Cam Gear, align the timing marks.

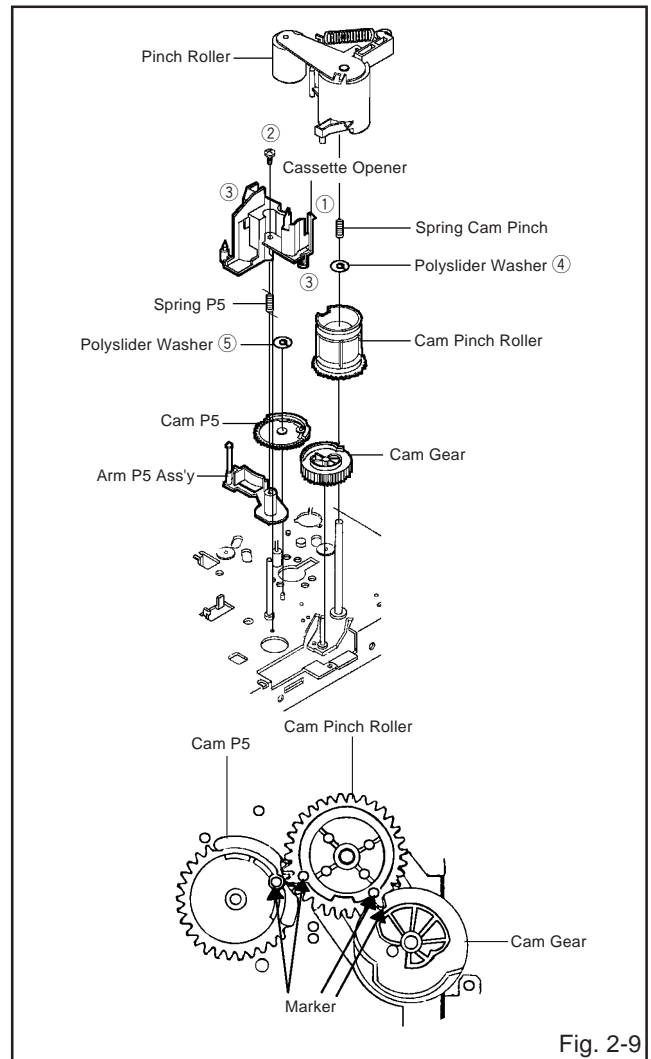

Fig. 2-9

2-10: AUDIO CONTROL HEAD (Refer to Fig. 2-10)

1. Remove the 3 screws ①.
2. Remove the 3 Audio Control Head Springs.
3. Remove the Audio Control Head.

NOTES

1. Do not touch the head by any means when replacing the Audio Control Head. (Use gloves.)
2. After replacement, confirm the following adjustments.
 - a. MECHANICAL ADJUSTMENTS: ITEM 2-2
 - b. MECHANICAL ADJUSTMENTS: ITEM 2-3

DISASSEMBLY INSTRUCTIONS

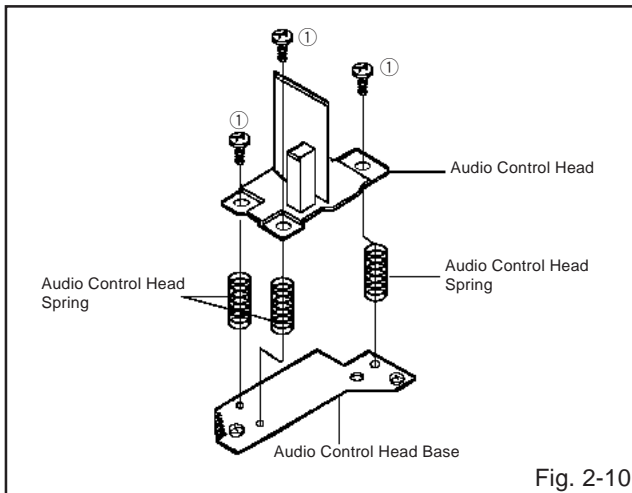

Fig. 2-10

2-11: CYLINDER UNIT (Refer to Fig. 2-11)

1. Remove the Joint Screw, then remove the Azimuth Spring.
2. Remove the 2 screws ①, then remove the Polyslider Washer and Cylinder Unit from the Main Chassis.

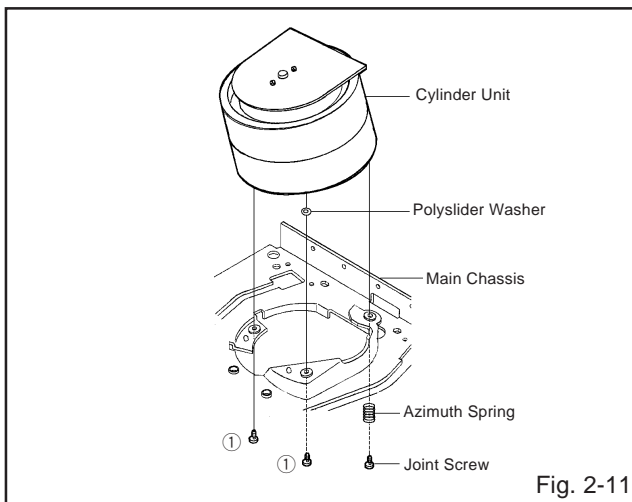

Fig. 2-11

2-12: PLATE BOTTOM (Refer to Fig. 2-12)

1. Remove the Capstan Belt.
2. Remove the 2 screws ①.
3. Remove the 3 screws ②.
4. Remove the Mode Switch.
5. Remove the Tension Lever Spring.
6. Remove the Plate Bottom.

NOTE

When installing the Mode Switch, align the timing position.

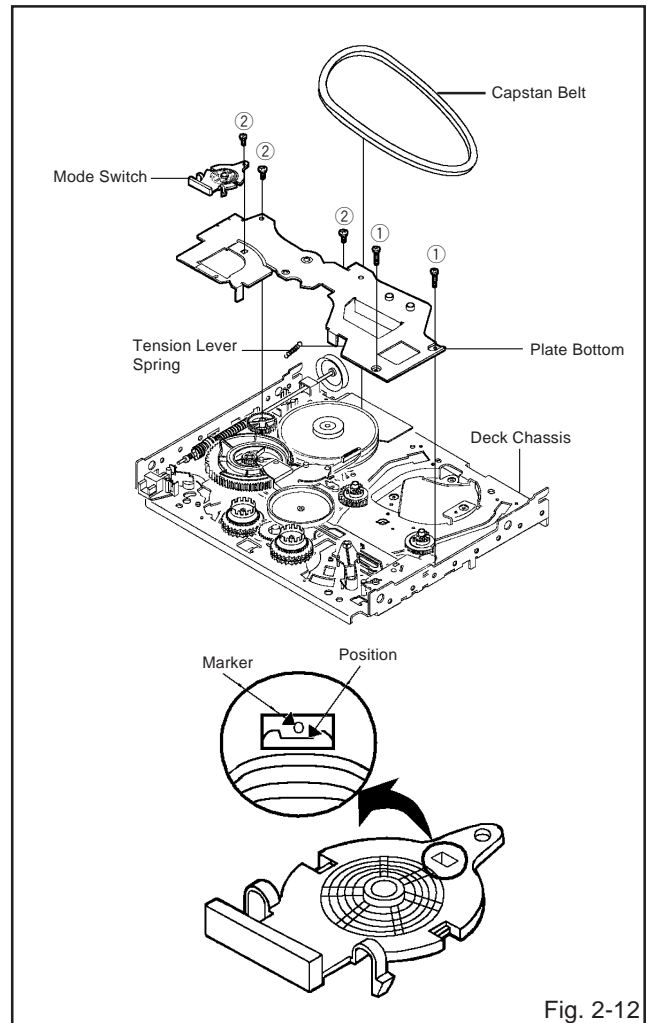

Fig. 2-12

2-13: CENTER PULLEY (Refer to Fig. 2-13)

1. Remove the Polyslider Washer ①.
2. Remove the Center Pulley.
3. Remove the Polyslider Washer ②.
4. Remove the Center Pulley Spring.
5. Remove the Idler Arm Ass'y.
6. Remove the 2 Polyslider Washers ③.
7. Remove the Clutch Gear T Ass'y and Clutch Gear S Ass'y.

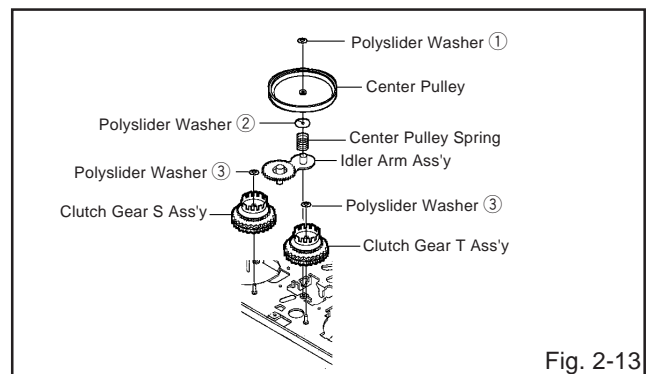

Fig. 2-13

DISASSEMBLY INSTRUCTIONS

2-14: MAIN CAM (Refer to Fig. 2-14)

1. Remove the Loading Lever.
2. Remove the Main Brake Lever.
3. Remove the Capstan Brake Spring.
4. Remove the Capstan Brake Ass'y.
5. Remove the Tension Holder.
6. Remove the Tension Lever.
7. Remove the Main Cam.
8. Remove the Middle Gear.
9. Remove the Main Rod Ass'y.

NOTES

1. When installing the Main Rod Ass'y, install side (B) first, then install side (A).
2. When installing the Loading Lever, align the timing marks.

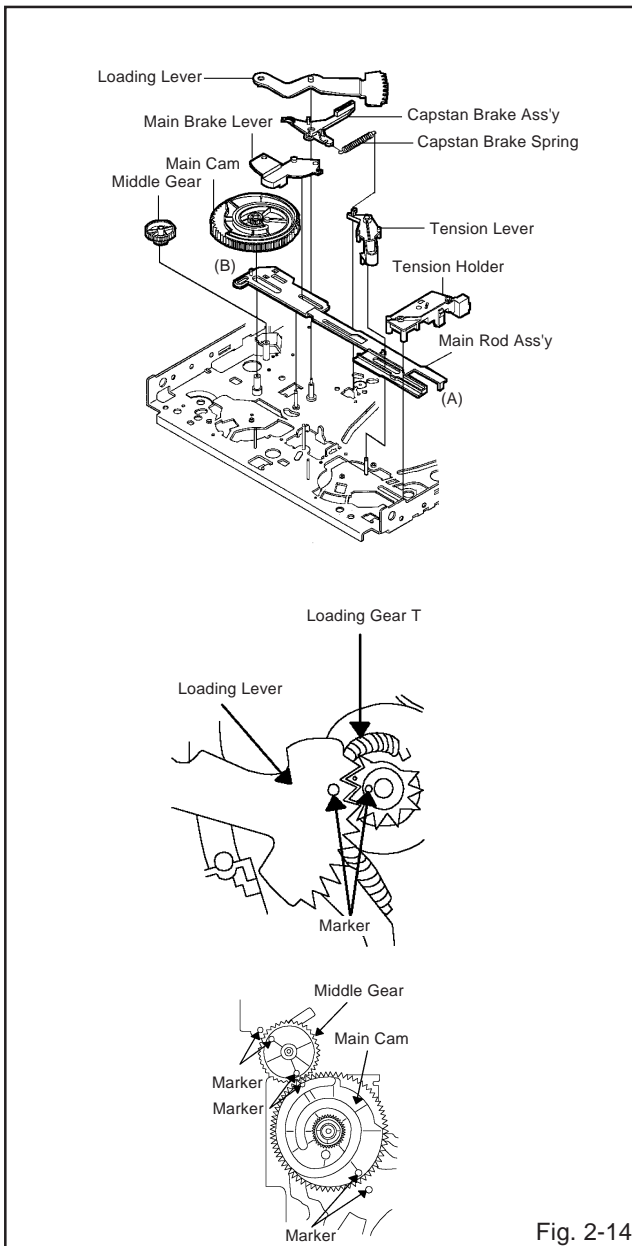

Fig. 2-14

2-15: CAPSTAN DD UNIT (Refer to Fig. 2-15)

1. Remove the 3 screws ①.
2. Remove the Capstan DD Unit.

NOTE

Use the specified screw to hold the Capstan DD Unit.

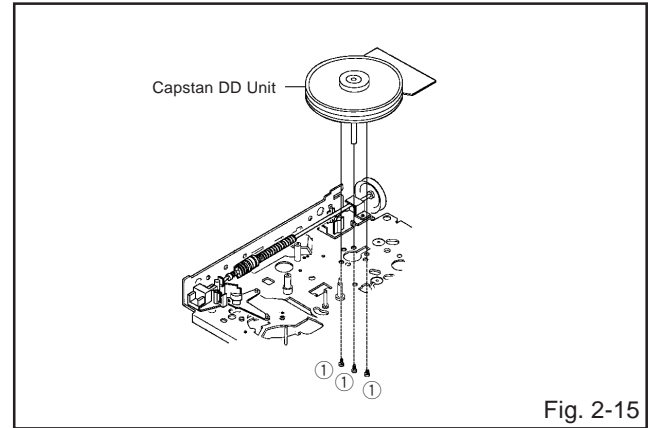

Fig. 2-15

2-16: INCLINED T ASS'Y / INCLINED S ASS'Y (Refer to Fig. 2-16)

1. Remove the 4 screws ①.
2. Remove the Catcher S and Catcher T.
3. Remove the 2 screws ②.
4. Remove the Slider Loadings.
5. Remove the Inclined T Ass'y and Inclined S Ass'y.
6. Remove the Loading Gear T Ass'y.
7. Remove the Loading Gear S Ass'y.

NOTE

When installing the Inclined T Ass'y and Inclined S Ass'y, align the timing marks.

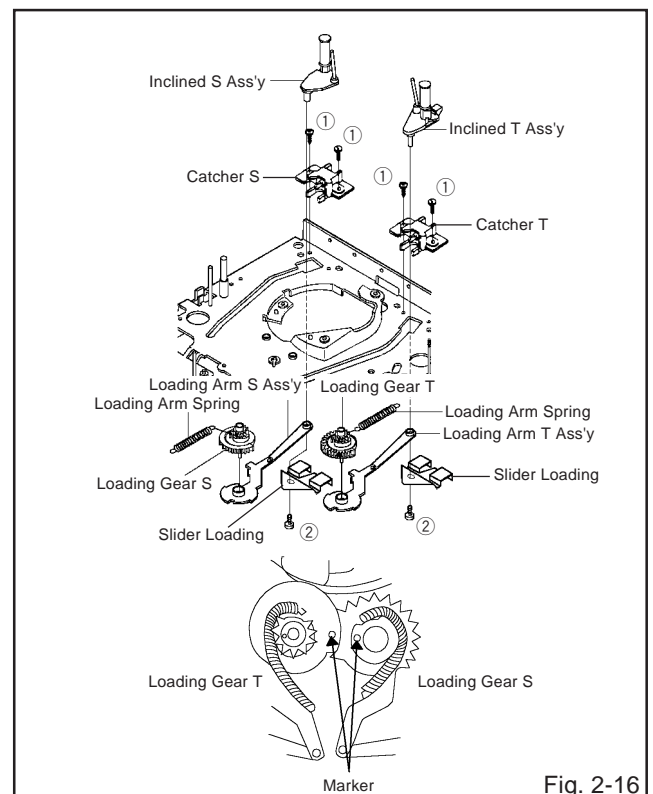

Fig. 2-16

DISASSEMBLY INSTRUCTIONS

3. REMOVAL OF ANODE CAP

Read the following **NOTED** items before starting work.

- * After turning the power off there might still be a potential voltage that is very dangerous. When removing the Anode Cap, make sure to discharge the Anode Cap's potential voltage.
- * Do not use pliers to loosen or tighten the Anode Cap terminal, this may cause the spring to be damaged.

REMOVAL

1. Follow the steps as follows to discharge the Anode Cap. (Refer to Fig. 3-1.)

Connect one end of an Alligator Clip to the metal part of a flat-blade screwdriver and the other end to ground. While holding the plastic part of the insulated screwdriver, touch the support of the Anode with the tip of the screwdriver.

A cracking noise will be heard as the voltage is discharged.

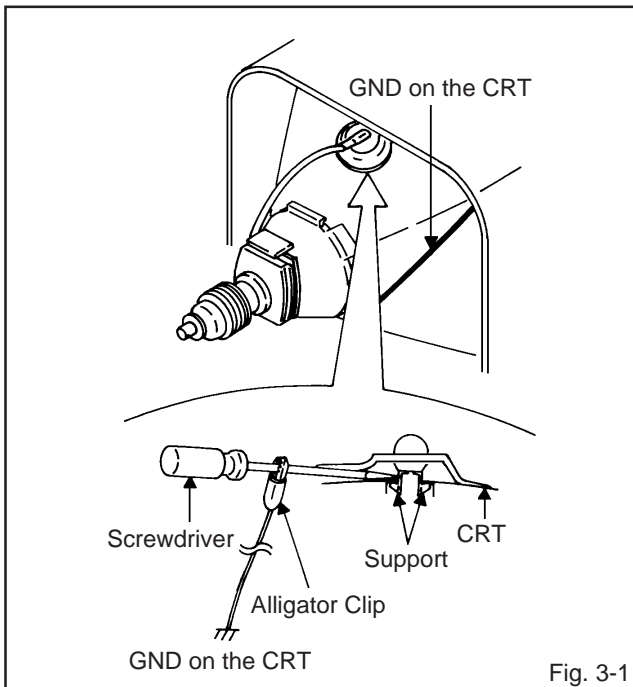

Fig. 3-1

2. Flip up the sides of the Rubber Cap in the direction of the arrow and remove one side of the support. (Refer to Fig. 3-2.)

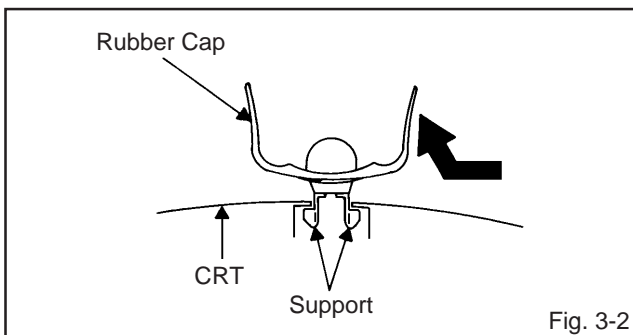

Fig. 3-2

3. After one side is removed, pull in the opposite direction to remove the other.

NOTE

Take care not to damage the Rubber Cap.

INSTALLATION

1. Clean the spot where the cap was located with a small amount of alcohol. (Refer to Fig. 3-3.)

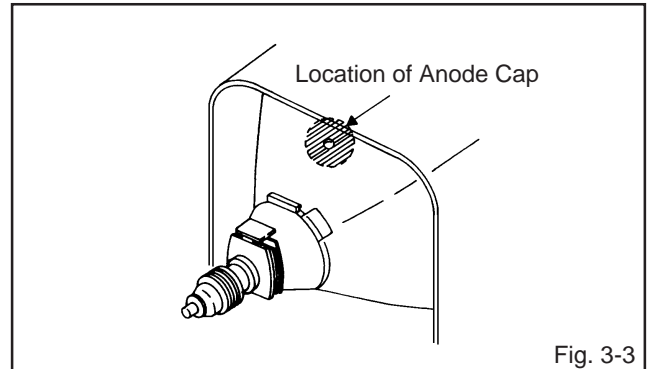

Fig. 3-3

NOTE

Confirm that there is no dirt, dust, etc. at the spot where the cap was located.

2. Arrange the wire of the Anode Cap and make sure the wire is not twisted.
3. Turn over the Rubber Cap. (Refer to Fig. 3-4.)

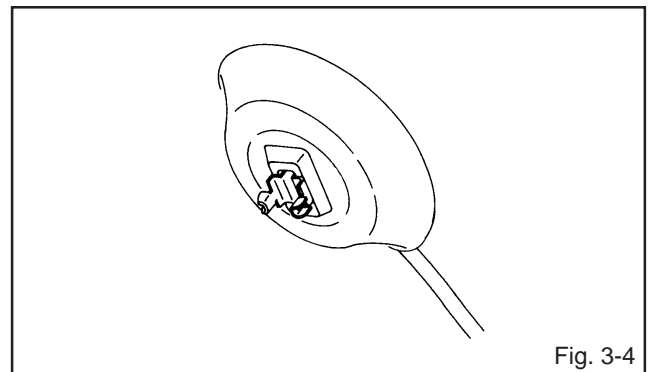

Fig. 3-4

4. Insert one end of the Anode Support into the anode button, then the other as shown in Fig. 3-5.

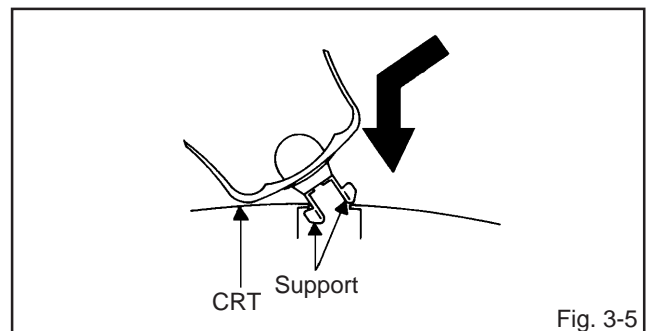

Fig. 3-5

5. Confirm that the Support is securely connected.
6. Put on the Rubber Cap without moving any parts.

KEY TO ABBREVIATIONS

A	A/C	: Audio/Control	H.SW	: Head Switch	
	ACC	: Automatic Color Control	Hz	: Hertz	
	AE	: Audio Erase	I	IC	: Integrated Circuit
	AFC	: Automatic Frequency Control		IF	: Intermediate Frequency
	AFT	: Automatic Fine Tuning		IND	: Indicator
	AFT DET	: Automatic Fine Tuning Detect		INV	: Inverter
	AGC	: Automatic Gain Control	K	KIL	: Killer
	AMP	: Amplifier	L	L	: Left
	ANT	: Antenna		LED	: Light Emitting Diode
	A.PB	: Audio Playback		LIMIT AMP	: Limiter Amplifier
	APC	: Automatic Phase Control		LM, LDM	: Loading Motor
	ASS'Y	: Assembly		LP	: Long Play
	AT	: All Time		L.P.F	: Low Pass Filter
	AUTO	: Automatic		LUMI.	: Luminance
	A/V	: Audio/Video	M	M	: Motor
B	BGP	: Burst Gate Pulse		MAX	: Maximum
	BOT	: Beginning of Tape		MINI	: Minimum
	BPF	: Bandpass Filter		MIX	: Mixer, mixing
	BRAKE SOL	: Brake Solenoid		MM	: Monostable Multivibrator
	BUFF	: Buffer		MOD	: Modulator, Modulation
	B/W	: Black and White		MPX	: Multiplexer, Multiplex
C	C	: Capacitance, Collector		MS SW	: Mech State Switch
	CASE	: Cassette	N	NC	: Non Connection
	CAP	: Capstan		NR	: Noise Reduction
	CARR	: Carrier	O	OSC	: Oscillator
	CH	: Channel		OPE	: Operation
	CLK	: Clock	P	PB	: Playback
	CLOCK (SY-SE)	: Clock (Syscon to Servo)		PB CTL	: Playback Control
	COMB	: Combination, Comb Filter		PB-C	: Playback-Chrominance
	CONV	: Converter		PB-Y	: Playback-Luminance
	CPM	: Capstan Motor		PCB	: Printed Circuit Board
	CTL	: Control		P. CON	: Power Control
	CYL	: Cylinder		PD	: Phase Detector
	CYL-M	: Cylinder-Motor		PG	: Pulse Generator
	CYL SENS	: Cylinder-Sensor		P-P	: Peak-to Peak
D	DATA (SY-CE)	: Data (Syscon to Servo)	R	R	: Right
	dB	: Decibel		REC	: Recording
	DC	: Direct Current		REC-C	: Recording-Chrominance
	DD Unit	: Direct Drive Motor Unit		REC-Y	: Recording-Luminance
	DEMODO	: Demodulator		REEL BRK	: Reel Brake
	DET	: Detector		REEL S	: Reel Sensor
	DEV	: Deviation		REF	: Reference
E	E	: Emitter		REG	: Regulated, Regulator
	EF	: Emitter Follower		REW	: Rewind
	EMPH	: Emphasis		REV, RVS	: Reverse
	ENC	: Encoder		RF	: Radio Frequency
	ENV	: Envelope		RMC	: Remote Control
	EOT	: End of Tape		RY	: Relay
	EQ	: Equalizer	S	S. CLK	: Serial Clock
	EXT	: External		S. COM	: Sensor Common
F	F	: Fuse		S. DATA	: Serial Data
	FBC	: Feed Back Clamp		SEG	: Segment
	FE	: Full Erase		SEL	: Select, Selector
	FF	: Fast Forward, Flipflop		SENS	: Sensor
	FG	: Frequency Generator		SER	: Search Mode
	FL SW	: Front Loading Switch		SI	: Serial Input
	FM	: Frequency Modulation		SIF	: Sound Intermediate Frequency
	FSC	: Frequency Sub Carrier		SO	: Serial Output
	FWD	: Forward		SOL	: Solenoid
G	GEN	: Generator		SP	: Standard Play
	GND	: Ground		STB	: Serial Strobe
H	H.P.F	: High Pass Filter		SW	: Switch

KEY TO ABBREVIATIONS

S	SYNC	:	Synchronization
	SYNC SEP	:	Sync Separator, Separation
T	TR	:	Transistor
	TRAC	:	Tracking
	TRICK PB	:	Trick Playback
	TP	:	Test Point
U	UNREG	:	Unregulated
V	V	:	Volt
	VCO	:	Voltage Controlled Oscillator
	VIF	:	Video Intermediate Frequency
	VP	:	Vertical Pulse, Voltage Display
	V.PB	:	Video Playback
	VR	:	Variable Resistor
	V.REC	:	Video Recording
	VSF	:	Visual Search Fast Forward
	VSR	:	Visual Search Rewind
	VSS	:	Voltage Super Source
	V-SYNC	:	Vertical-Synchronization
	VT	:	Voltage Tuning
X	X'TAL	:	Crystal
Y	Y/C	:	Luminance/Chrominance

PREVENTIVE CHECKS AND SERVICE INTERVALS

The following standard table depends on environmental conditions and usage. Unless maintenance is properly carried out, the following service intervals may be quite shortened as harmful effects may be had on other parts. Also, long term storage or misuse may cause transformation and aging of rubber parts.

Time Parts Name	500 hours	1,000 hours	1,500 hours	2,000 hours	3,000 hours	Notes
Audio Control Head	■	■	■	■	■	Clean those parts in contact with the tape.
Full Erase Head	■	■	■	■	■	
Loading Motor Belt			■	■	●	Clean the rubber, and parts which the rubber touches.
Reel Belt			■	■	●	
Pinch Roller	■	■	■	■	■ ●	
Capstan DD Unit					●	
Loading Motor					●	
Tension Band					●	
Capstan Shaft	■	■	■	■	■	
Tape Running Guide Post	■	■	■	■	■	Replace when rolling becomes abnormal.
Cylinder Unit	■	■	■	■	●	Clean the Head.

● : Replace ■ : Clean

CLEANING

NOTE

- After cleaning the heads with isopropyl alcohol, do not run a tape until the heads dry completely. If the heads are not completely dry and alcohol gets on the tape, damage may occur.

1. AUDIO CONTROL HEAD

- Wrap a piece of chamois around your finger. Dip it in isopropyl alcohol and clean the audio control head by wiping it horizontally. Clean the full erase head in the same manner. **(Refer to the figure below)**

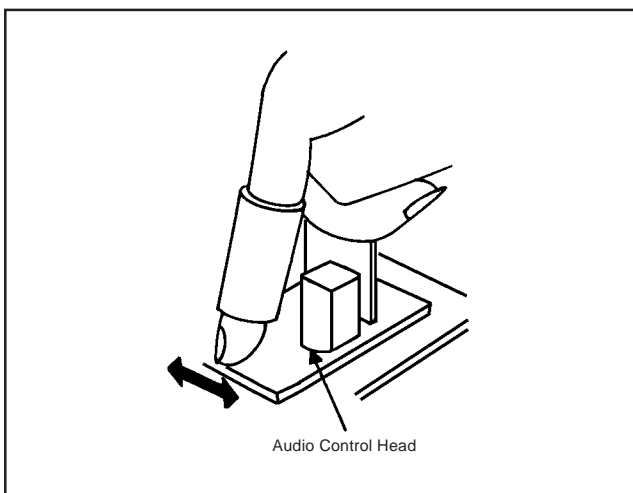

2. TAPE RUNNING SYSTEM

- When cleaning the tape transport system, use the gauze moistened with isopropyl alcohol.

3. CYLINDER

- Wrap a piece of chamois around your finger. Dip it in isopropyl alcohol. Hold it to the cylinder head softly. Turn the cylinder head counterclockwise to clean it (in the direction of the arrow). **(Refer to the figure below)**

NOTE

Do not exert force against the cylinder head. Do not move the chamois up or down since this can damage the head. Always use a piece of chamois for cleaning.

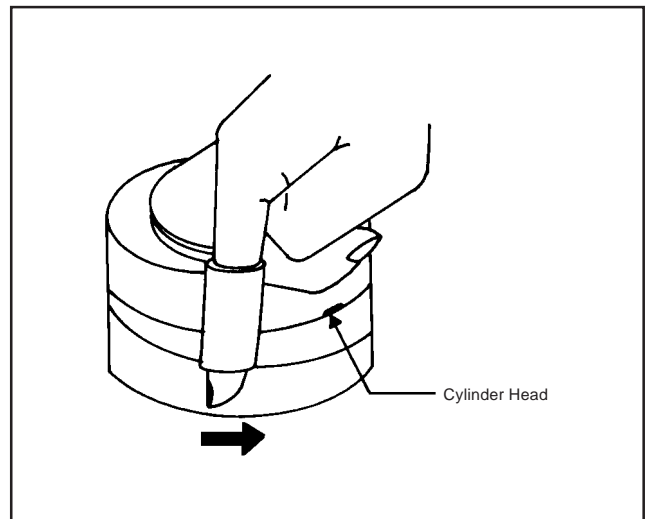

NOTE FOR THE REPLACING OF MEMORY IC

If a service repair is undertaken where it has been required to change the MEMORY IC, the following steps should be taken to ensure correct data settings while making reference to TABLE 1.

NOTE:

- Initial Data setting will not be possible if clock has been set. To reset clock, either unplug AC cord and allow at least 1 hour before Power On or alternatively, discharge backup capacitor.
- No need the setting for after INI 6.

ADDRESS	INI 01	INI 02	INI 03	INI 04	INI 05	INI 06
DATA	0C	09	2B	16	56	30

Table 1

1. Enter DATA SET mode by setting VOLUME to minimum.
2. While holding down VOLUME button on front cabinet, press key 6 on remote control simultaneously.
3. ADDRESS and DATA should appear as FIG 1.

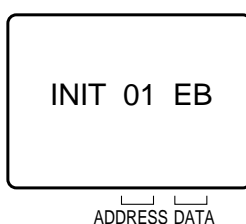
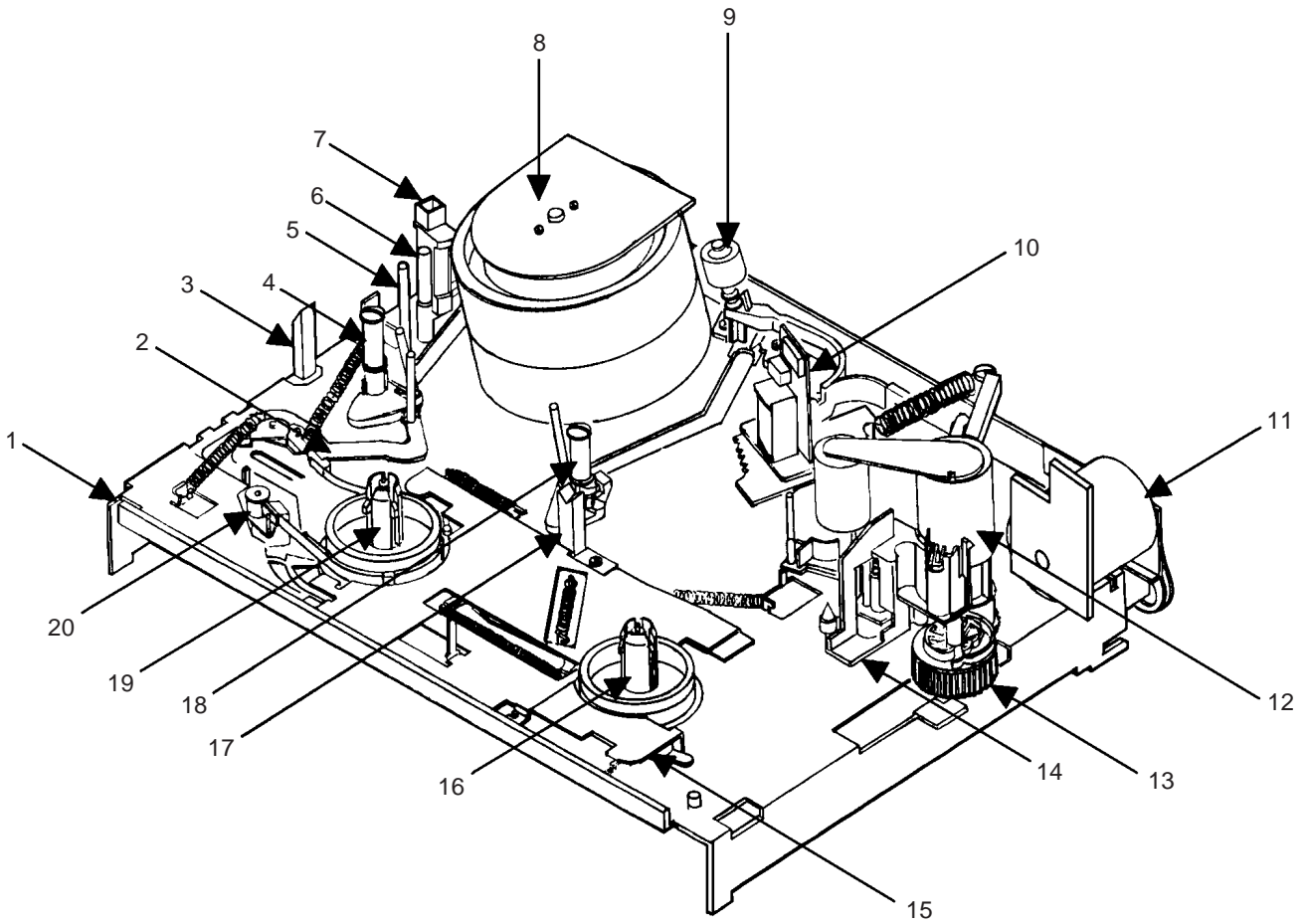

Fig. 1

4. ADDRESS is now selected and should "blink". Using the SET + or - keys on the remote, step through the ADDRESS until required ADDRESS to be changed is reached.
5. Press ENTER to select DATA. When DATA is selected, it will "blink".
6. Again, step through the DATA using SET + or - until required DATA value has been selected.
7. Pressing ENTER will take you back to ADDRESS for further selection if necessary.
8. Repeat steps 4 to 7 until all data has been checked.
9. When satisfied correct DATA has been entered, turn POWER off (return to STANDBY MODE) to finish DATA input. The unit will now have the correct DATA for the new MEMORY IC.

DECK PARTS LOCATIONS

(TOP VIEW)



- | | |
|-------------------------|--------------------------|
| 1. Main Chassis | 11. Loading Motor Ass'y |
| 2. Tension Arm Ass'y | 12. Pinch Roller Block |
| 3. EOT Reflector | 13. Cam Gear |
| 4. Guide Roller S Ass'y | 14. Cassette Opener |
| 5. P0 Post | 15. Brake Bracket |
| 6. P1 Post | 16. Reel T |
| 7. FE Head | 17. LED Reflector |
| 8. Cylinder Unit | 18. Guide Roller T Ass'y |
| 9. Auto Head Cleaning | 19. Reel S |
| 10. Audio/Control Head | 20. Tension Band Ass'y |

DECK PARTS LOCATIONS (BOTTOM VIEW)

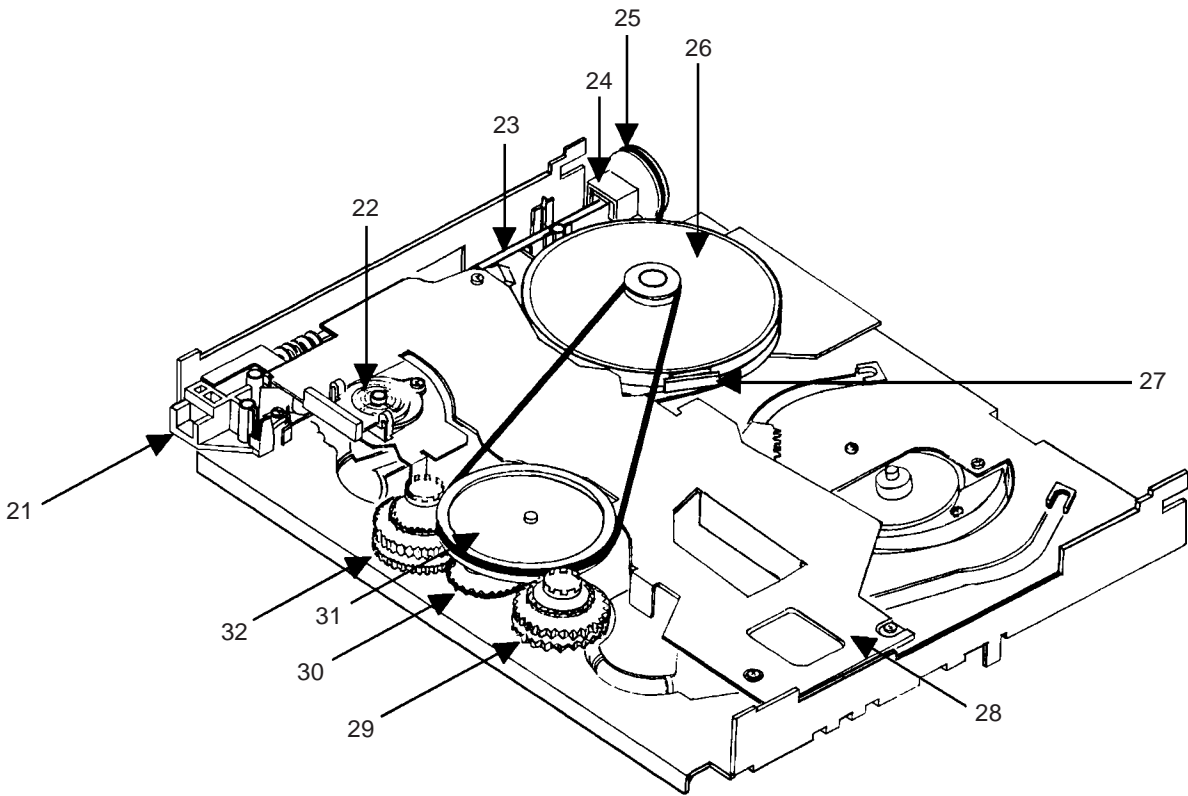

- | | |
|--------------------------|-------------------------|
| 21. Worm Bracket F Ass'y | 27. Capstan Brake Ass'y |
| 22. Mode Switch | 28. Bottom Plate |
| 23. Worm Ass'y | 29. Clutch Gear S Ass'y |
| 24. Worm Bracket R Ass'y | 30. Idler Arm Ass'y |
| 25. Loading Motor Belt | 31. Center Pulley |
| 26. Capstan DD Unit | 32. Clutch Gear T Ass'y |

(FRONT LOADING UNIT 15)

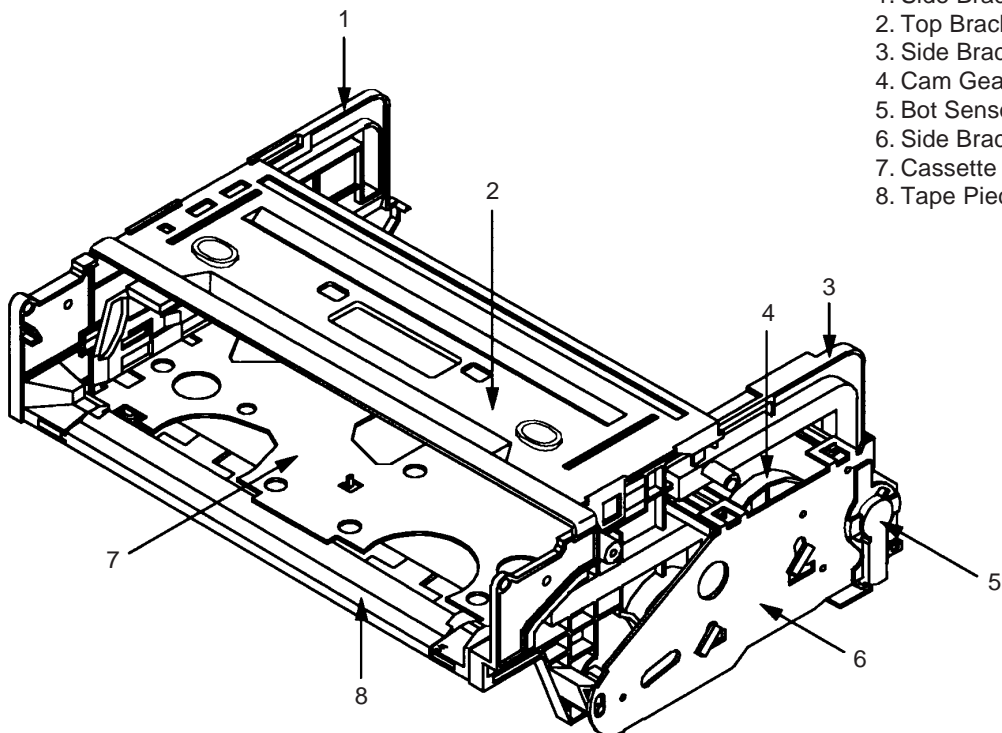

1. Side Bracket L
2. Top Bracket Ass'y
3. Side Bracket R Ass'y
4. Cam Gear Ass'y
5. Bot Sensor Cover
6. Side Bracket R2
7. Cassette Holder Ass'y
8. Tape Piece Guide

SERVICING FIXTURES AND TOOLS

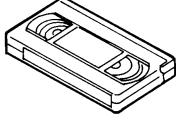
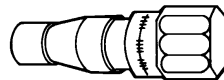
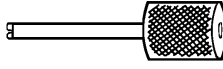
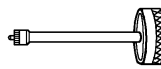
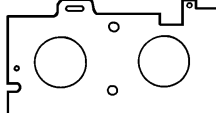
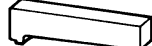
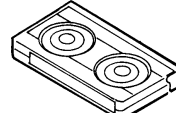
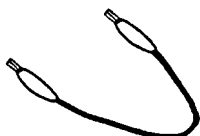
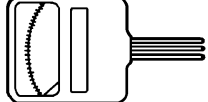
VHS Alignment Tape JG001 (VN ₂ S-LI6 ³) JG001A (VN ₂ S-CO1 ³) 	JG002B Adapter JG002F Dial Torque Gauge (60~600gf•cm) JG002G (100~1200gf•cm) 	JG005 Post Adjustment Screwdriver Part No. SV-TG0-030-000 (small) 	JG153 X Value Adjustment Screwdriver 
JG022 Master Plane 	JG024 Reel Disk Height Adjustment Jig 	JG100A Torque Tape (VHT-063) 	JG154 Cable 
Tentelometer 			

Part No.	Remarks
JG001	Monoscope, 6KHz
JG001A	Color Bar, 1KHz
JG002F	Playback Take Up Torque
JG002G	Fast Forward Torque, Rewind Torque, Brake Torque (Take up Reel/Supply Reel)
JG005	Guide Roller Adjustment
JG153	X-Value Adjustment
JG022/JG024	Reel Disk Height Adjustment
JG100A	Playback Back Tension Torque
JG154	Used to connect the test point of SERVICE and GROUND

PREPARATION FOR SERVICING

How to use the Servicing Fixture

1. Short circuit between **TP1001** and **TP1002** with the cable JG154.

(Refer to MAJOR COMPONENTS LOCATION GUIDE)

The EOT, BOT and Reel Sensor do not work at this moment.

At that time, the STOP/EJECT button is available to insert and eject the Cassette Tape.

MECHANICAL ADJUSTMENTS

1. CONFIRMATION AND ADJUSTMENT

Read the following NOTED items before starting work.

- Place an object which weighs between 350g and 500g on the Cassette Tape to keep it steady when you want to make the tape run without the Front Loading Unit 15. (Do not place an object which weighs over 500g.)
- When you activate the deck without the Front Loading Unit 15, short circuit between **TP1001** and **TP1002**. In this condition the BOT/EOT/Reel Sensor will not function.

1-1: CONFIRMATION AND ADJUSTMENT OF REEL DISK HEIGHT

1. Turn on the power and set to the STOP mode.
2. Set the master plane (**JG022**) and reel disk height adjustment jig (**JG024**) on mechanism framework, taking care not to scratch the drum, as shown in **Fig. 1-1-A**.
3. Confirm that the reel disk is lower than "A" of the reel disk height adjustment jig (**JG024**) on the master plane and higher than "B" as shown in **Fig. 1-1-B**. If it is not, adjust to less than $7.5\text{mm} \pm 0.2\text{mm}$ with the height adjustment washer.
4. Perform the same adjustment for other reel.

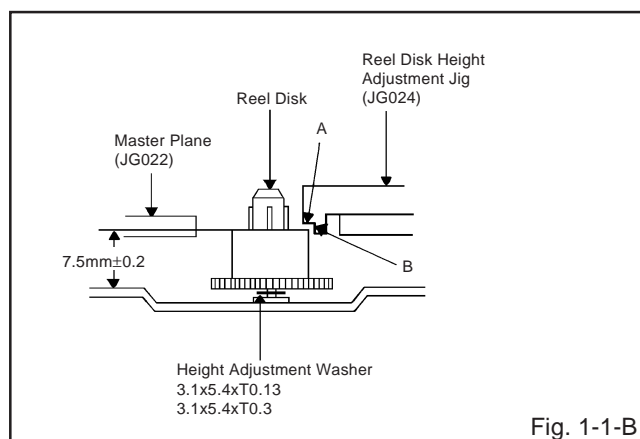
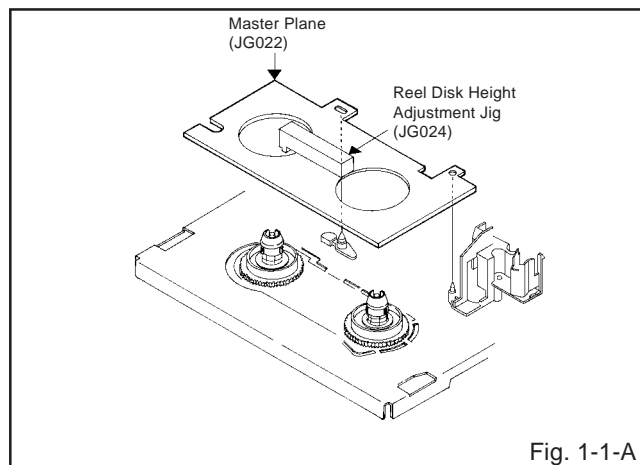

1-2: CONFIRMATION AND ADJUSTMENT OF TENSION POST POSITION

1. Turn on the power and set to the PLAY mode adjust the Tension so that the Tension Post is at the position of 0.3mm~0.5mm from the Rib. (**Refer to Fig. 1-2**)
2. Confirm that the video tape is not curling at the flange of P1 post or is not running on flanges.

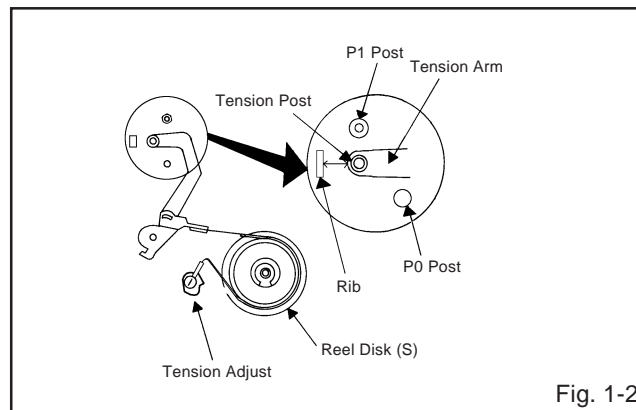

1-3: CONFIRMATION AND ADJUSTMENT OF BACK TENSION ON PLAYBACK

1. Load a video tape recorded in standard speed mode. Set the unit to the PLAY mode.
 2. Install the tentelometer as shown in **Fig. 1-3**. Confirm the value is within 20~27gf at this time.
- IN CASE OF USING A CASSETTE TYPE TORQUE TAPE.
1. After adjustment, confirm and adjust the tension post position (**Refer to item 1-2**) for the tension arm, install the cassette type torque tape (**JG100A**) and set to the PLAY mode.
 2. Confirm that the left hand side tension value of the torque tape is 25~38gf•cm for the standard mode tape.

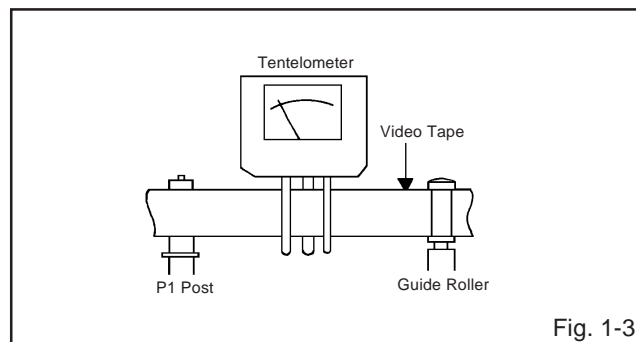

MECHANICAL ADJUSTMENTS

1-4: CONFIRMATION OF FAST FORWARD TORQUE

1. Set torque gauge (**JG002G**) on take-up reel disk, and place unit in FAST FORWARD mode. (Refer to Fig. 1-4)
2. Confirm that torque is more than 400gf•cm.

NOTE

After setting the torque gauge on the reel disk, hold the gauge in place.
Push the FAST FORWARD button and the reel disk will begin to turn.

1-5: CONFIRMATION OF REWIND TORQUE

1. Operate within 4 or 5 seconds after the reel disk begins to turn.
2. Set torque gauge (**JG002G**) on supply reel disk, and place the unit in REWIND mode. (Refer to Fig. 1-4).
3. Confirm that torque is more than 400gf•cm.

NOTE

After setting the torque gauge on the reel disk, hold the gauge in place.
Push the REWIND button and the reel disk will begin to turn.

1-6: CONFIRMATION OF REEL BRAKE TORQUE

(Take-Up Reel Brake) (Refer to Fig. 1-4)

1. Set to STOP mode.
2. Set the torque gauge (**JG002G**) to the take-up reel and turn it counterclockwise.
3. Confirm that it is more than 45 ± 10 gf•cm at that time.

(Supply Reel Brake) (Refer to Fig. 1-4)

1. Set to STOP mode.
2. Set the torque gauge (**JG002G**) to the supply reel and turn it clockwise.
3. Confirm that it is more than 95 ± 40 gf•cm at that time.

NOTE

Separate the idler from the reel and confirm the brake torque.

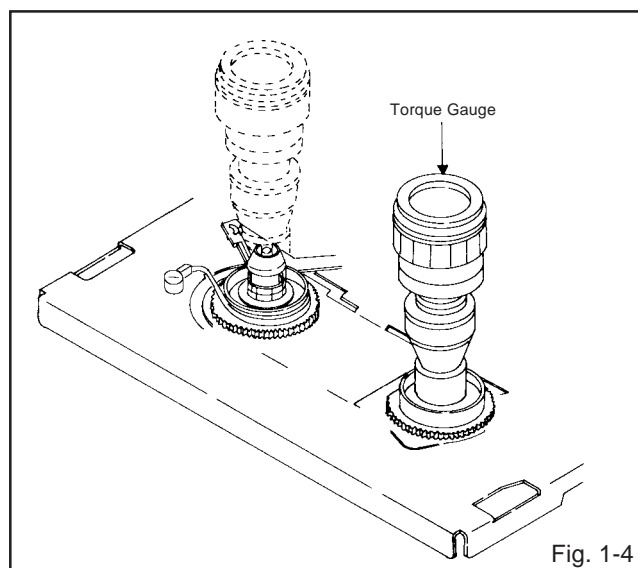

NOTE

If the torque value checked is out of tolerance, replace the appropriate parts as follows.

Check Items	Replace Parts
1-4	Idler Ass'y or Clutch ASS'Y
1-5	Idler Ass'y or Clutch ASS'Y
1-6	Main Brake T Ass'y or Main Brake S Ass'y

2. TAPE RUNNING CONFIRMATION AND ADJUSTMENT

- Tape running is adjusted precisely at the factory. Normally, it is not necessary to make adjustments. It is necessary to confirm and make adjustments when the parts of the tape running mechanism are replaced because of extensive usage or failure.

2-1: GUIDE ROLLER

1. Connect CH-1 on the oscilloscope to **TP4102 (PB Envelope)** and CH-2 to **TP4101 (SW Pulse)**.
2. Set the tracking to manual center position in the following way. Press and hold the tracking auto button more than 2 seconds to set the tracking to center position.
3. Trigger with SW pulse and observe the envelope. (Refer to Fig. 2-1-A)
4. Adjust the guide roller height while observing the envelope, and make the envelope flat. Adjust the envelope so that the flatness will not be affected even when the tracking control button is pressed. (Use the adjustment screwdriver **JG005**).
5. Press and hold the tracking control button and (at the point that the envelope waveform starts to reduce) adjust the envelope so that the A : B ratio is better than 3 : 2. (Refer to Fig. 2-1-B)
6. Adjust the PG shifter (**ELECTRICAL ADJUSTMENTS : ITEM 3-1**) in the PLAY mode.

NOTE

After adjustment, confirm and adjust A/C head tilt. (Refer to item 2-2)

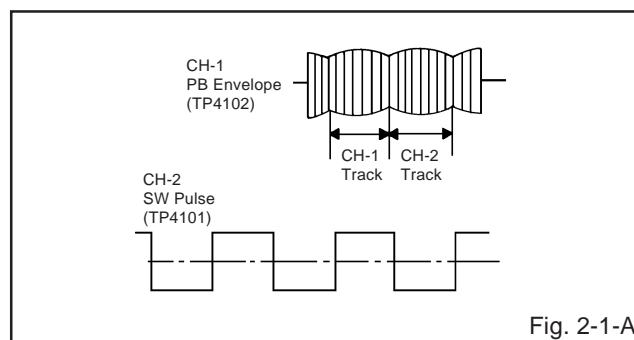

MECHANICAL ADJUSTMENTS

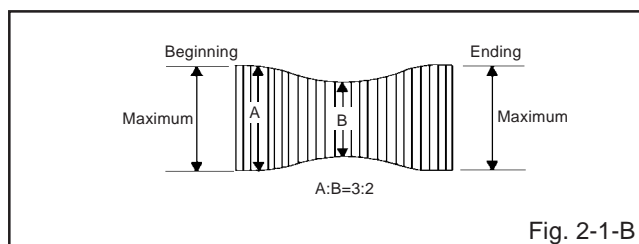

2-2: CONFIRMATION AND ADJUSTMENT OF A/C HEAD TILT

When the tape is running abnormally, perform the following adjustments.

1. Insert a new tape and play it back.
2. Confirm that there is no crease on the tape between the P4 post and guide roller (R) and the tape is running smoothly. (It is absolutely impossible to get satisfactory sound if the tape is distorted between the A/C head and P4 post.)
3. If the tape still does not run smoothly, turn the screw ① and adjust the tilt of the A/C head. (Refer to Fig. 2-2)

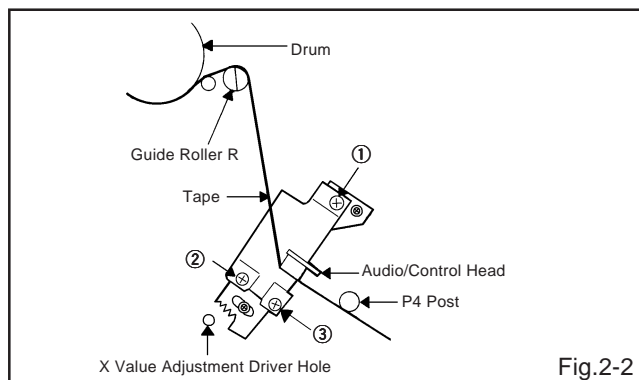

2-3: ADJUSTMENT OF A/C HEAD HEIGHT AND AZIMUTH

1. Playback a VHS alignment tape (JG001) and observe the waveform at the audio output terminal.
2. Turn the screw ② slowly to change the azimuth of the A/C head. Adjust the height so that the audio output becomes maximum. (Refer to Fig. 2-2)
3. Adjust the screw ③, (Refer to Fig. 2-2) until the height of the A/C head reaches the position against the tape as shown in Fig. 2-3.
4. When the control head height is not correct. (When you must turn the screw more than 45 degrees), Turn all of the screws ①, ② and ③ to the same degrees. Then confirm the angle of the audio/control head and adjust again.

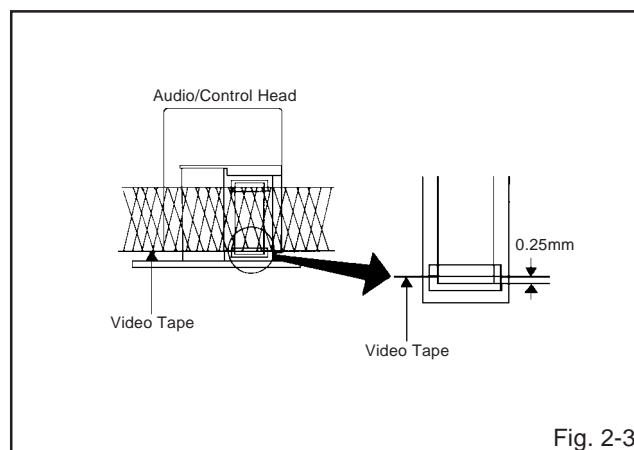

2-4: TAPE RUNNING ADJUSTMENT

1. Adjust the height of reel disk. (Refer to item 1-1)
2. Confirm and adjust tension post position. (Refer to item 1-2)
3. Adjust the guide roller. (Refer to item 2-1)
4. Adjust the A/C head tilt. (Refer to item 2-2)
5. Adjust the A/C head height and azimuth. (Refer to item 2-3)
6. Connect CH-1 on the oscilloscope to TP4101 and CH-2 to TP4102. Playback the VHS alignment tape (JG001). Set the tracking to manual center. Adjust X with the screw driver for X (JG153) as the Fig. 2-1-A and Fig. 2-1-B. (Refer to No. 2 of the item 2-1).

ELECTRICAL ADJUSTMENTS

(VCR SECTION)

3. ADJUSTMENT PROCEDURE

Read and perform these adjustments when repairing the circuits or replacing electrical parts or PCB assemblies.

CAUTION

When replacing IC's or transistors, use only specified silicon grease (**YG6260M**).

(To prevent the damage to IC's and transistors.)

On-Screen Display Adjustment

1. Set the volume level to minimum after unplugging the power cord once from the AC source in order to set the TV/VCR to the reset mode.
2. Press the VOL. DOWN on the set and the channel button **(9)** on the remote control simultaneously to display adjustment mode on the screen as shown in **Fig. 3-1, Fig. 3-2, Fig. 3-3 and Fig. 3-4.**

NOTE

Use the 1-8 keys on the remote control to select the options shown in **Fig. 3-1, Fig. 3-2, Fig. 3-3 and Fig. 3-4.** Press the 8 key to end the adjustments.

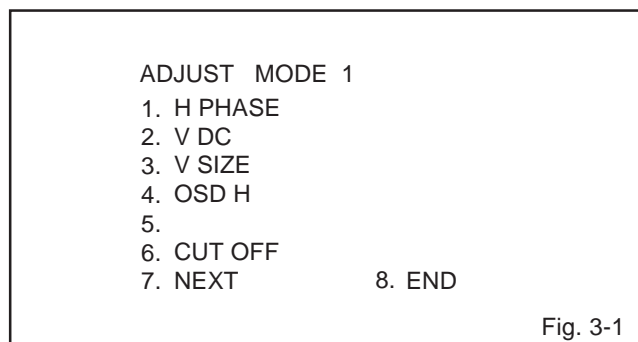

Fig. 3-1

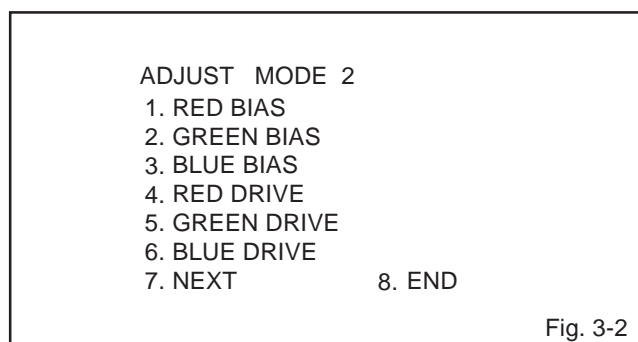

Fig. 3-2

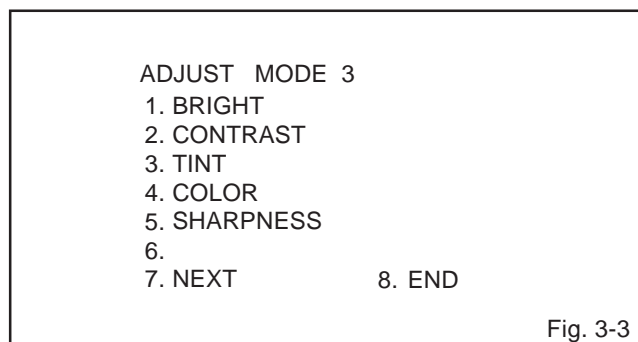

Fig. 3-3

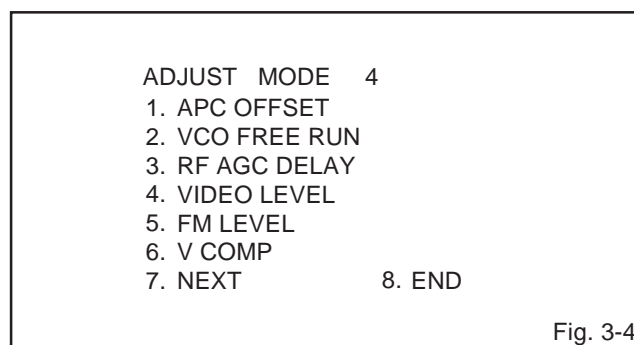

Fig. 3-4

3-1: PG SHIFTER

1. Playback the alignment tape. (**JG001**)
2. Set the volume level to minimum after unplugging the power cord once from the AC source in order to set the TV/VCR to the reset mode.
3. Press the VOL. DOWN button on the set and the channel button **(3)** on the remote control simultaneously until the indicator REC disappears. If the indicator REC disappears, adjustment is completed.

(If the above adjustments doesn't work well;)

1. Connect CH-1 on the synchro scope to **TP4101** and CH-2 to **TP4201**.
2. Playback the alignment tape. (**JG001**)
3. Press the VOL. DOWN button on the set and the channel button **(4)** on the remote control simultaneously.
4. Adjust the Tracking +/- key so that the waveform of the synchro scope measures $6.5 \pm 0.5(H)$ at both leading and trailing edges. (**Refer to Fig. 3-5-A, B**)
5. Press the Tracking Auto key.

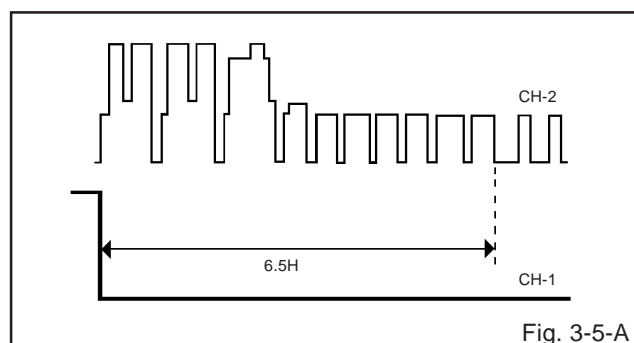

Fig. 3-5-A

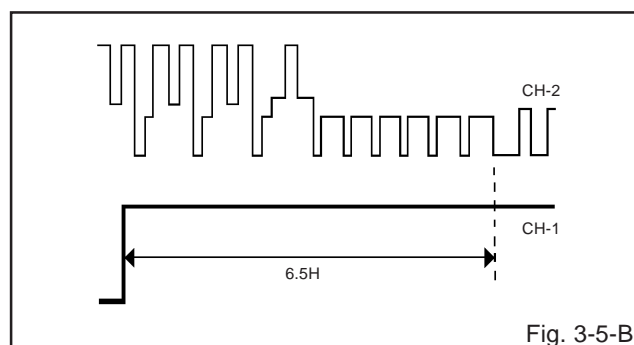

Fig. 3-5-B

ELECTRICAL ADJUSTMENTS

3-2: VCO FREE RUN

1. Connect the DC voltmeter between the **pin 6 of CP830** and the **pin 1 (GND) of CP830**.
2. Receive an 80dB monoscope signal at the tuner antenna input (using a VHF channel frequency).
3. Activate the adjustment mode display of **Fig. 3-4** and press the channel button **(2)** on the remote control.
4. Press the VOL.UP/DOWN button on the remote control until the VCO FREE RUN level becomes 64 ± 5 steps.
5. Adjust **L603** until the DC voltmeter is $2.8 \pm 0.2V$.

3-3: RF AGC DELAY

1. Connect the DC voltmeter between the **pin 5 of CP830** and the **pin 1 (GND) of CP830**.
2. Receive an 80dB monoscope signal at the tuner antenna input (using a VHF channel frequency).
3. Activate the adjustment mode display of **Fig. 3-4** and press the channel button **(3)** on the remote control.
4. Press the VOL.UP/DOWN button on the remote control until the DC voltmeter is $4.0 \pm 0.2V$.

(TV SECTION)

4. BASIC ADJUSTMENTS

4-1: CUT OFF

1. Activate the adjustment mode display of **Fig. 3-1** and press the channel button **(6)** on the remote control.
2. Adjust the **Screen Volume** until a dim raster is obtained.

4-2: WHITE BALANCE

NOTE

Adjust after performing adjustments in section 4-1.

1. Receive the color bar pattern.
2. Adjust from the adjustment mode display of **Fig. 3-2** until the white color of color bar becomes white.

4-3: FOCUS

1. Receive a monoscope signal sharper than 70dB at the tuner antenna input.
2. Adjust the **Focus Volume** until picture is distinct.

4-4: HORIZONTAL POSITION

1. Receive the monoscope pattern.
2. Using the remote control, set brightness to normal position and set contrast to maximum position.
3. Activate the adjustment mode display of **Fig. 3-1** and press the channel button **(1)** on the remote control.
4. Press the VOL.UP/DOWN button on the remote control until the right and left screen edges are equal.

4-5: VERTICAL POSITION

1. Receive the monoscope pattern.
2. Using the remote control, set brightness to normal position and set contrast to maximum position.
3. Activate the adjustment mode display of **Fig. 3-1** and press the channel button **(2)** on the remote control.
4. Press the VOL.UP/DOWN button on the remote control until the horizontal line of the monoscope come to approximate center of the CRT.

4-6: VERTICAL SIZE

1. Receive the monoscope pattern.
2. Using the remote control, set brightness to normal position and set contrast to maximum position.
3. Activate the adjustment mode display of **Fig. 3-1** and press the channel button **(3)** on the remote control.
4. Press the VOL.UP/DOWN button on the remote control until the horizontal overscan is equal to the vertical

4-7: SUB COLOR, SUB BRIGHT, SUB TINT (TV,AV)

4-7-A: SUB COLOR (TV)

1. Receive the color bar pattern.(RF Input)
2. Connect the synchro scope to **TP801**.
3. Activate the adjustment mode display of **Fig. 3-3** and press the channel button **(4)** on the remote control.
4. Adjust the VOLT RANGE VARIABLE knob of the synchro scope until the range between white 0% and 100% is set to 4 scales on the screen of the synchro scope.
5. Press the VOL.UP/DOWN button on the remote control until the red color level is adjusted to 4 scales ($100\% \pm 5\%$) for the white level.(Refer to **Fig. 4-1**)

ELECTRICAL ADJUSTMENTS

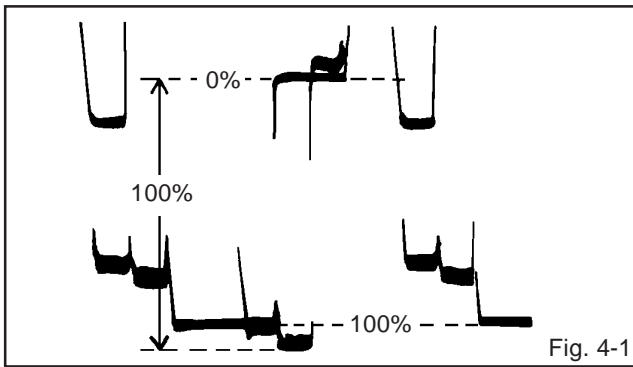

4-7-B: SUB COLOR (AV)

1. Receive the color bar pattern.(Audio Video Input)
2. Connect the synchro scope to **TP801**.
3. Activate the adjustment mode display of **Fig. 3-3** and press the channel button **(4)** on the remote control.
4. Press the TV/AV button on the remote control to select AV input.
5. Adjust the VOLT RANGE VARIABLE knob of the synchro scope until the range between white 0% and 100% is set to 4 scales on the screen of the synchro scope.
6. Press the VOL.UP/DOWN button on the remote control until the red color level is adjusted to 4 scales (100% \pm 5%) for the white level.(Refer to **Fig. 4-1**)

4-7-C: SUB BRIGHT (TV)

1. Receive the monoscope pattern.(RF Input)
2. Using the remote control, set brightness to normal position and set contrast to maximum position.
3. Activate the adjustment mode display of **Fig. 3-3** and press the channel button **(1)** on the remote control.
4. Press the VOL.UP/DOWN button on the remote control until the white 10% is starting to be visible.

4-7-D: SUB BRIGHT (AV)

1. Receive the monoscope pattern.(Audio Video Input)
2. Using the remote control, set brightness to normal position and set contrast to maximum position.
3. Activate the adjustment mode display of **Fig. 3-3** and press the channel button **(1)** on the remote control.
4. Press the TV/AV button on the remote control to select AV input.
5. Press the VOL.UP/DOWN button on the remote control until the white 10% is starting to be visible.

4-7-E: SUB TINT (TV)

1. Receive the color bar pattern. (RF Input)
2. Connect the synchro scope to **TP803**.
3. Activate the adjustment mode display of **Fig. 3-1** and press the channel button **(3)** on the remote control.
4. Press the VOL. UP/DOWN key on the remote control until the waveform becomes as shown in **Fig. 4-2**.

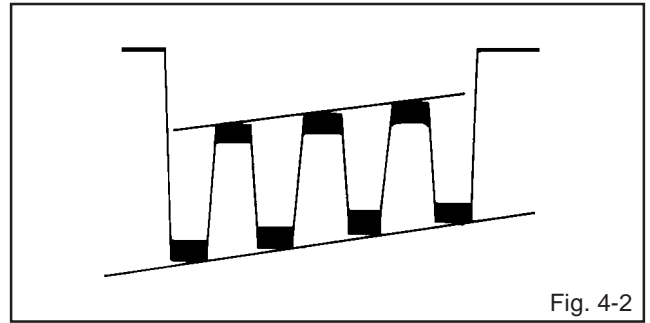

4-7-F: SUB TINT (AV)

1. Receive the color bar pattern. (Audio Video Input)
2. Connect the synchro scope to **TP803**.
3. Activate the adjustment mode display of **Fig. 3-3** and press the channel button **(3)** on the remote control.
4. Press the TV/AV button on the remote control to select AV input.
5. Press the VOL. UP/DOWN button on the remote control until the waveform becomes as shown in **Fig. 4-2**.

4-8: OSD HORIZONTAL

1. Using the remote control, set brightness to normal position and set contrast to maximum position.
2. Activate the adjustment mode display of **Fig. 3-1** and press the channel button **(4)** on the remote control.
3. Press the VOL. UP/DOWN on the remote control until the difference of A and B becomes equal. (Refer to **Fig. 4-3**)

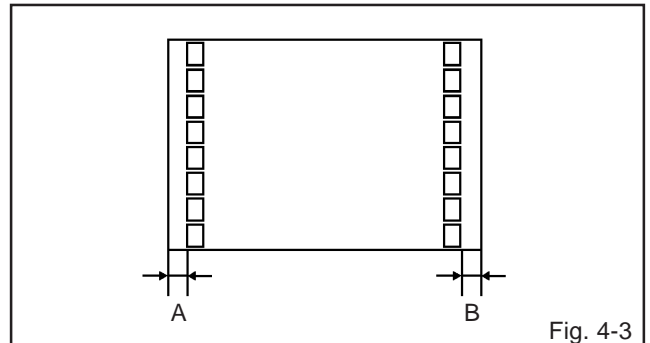

4-9: CONSTANT VOLTAGE

1. Receive the monoscope pattern.
2. Using the remote control, set the brightness to normal position and set contrast to maximum position.
3. Connect the digital voltmeter to **C528**.
4. Adjust the **VR502** until the DC voltage is $11.3 \pm 0.1V$.

ELECTRICAL ADJUSTMENTS

5. PURITY AND CONVERGENCE ADJUSTMENTS

NOTE

1. Turn the unit on and let it warm up for at least 30 minutes before performing the following adjustments.
2. Place the CRT surface facing east or west to reduce the terrestrial magnetism.
3. Turn ON the unit and demagnetize with a Degauss Coil.

5-1: STATIC CONVERGENCE (ROUGH ADJUSTMENT)

1. Tighten the screw for the magnet. Refer to the adjusted CRT for the position. **(Refer to Fig. 5-1)**
If the deflection yoke and magnet are in one body, untighten the screw for the body.
2. Receive the green raster pattern from the color bar generator.
3. Slide the deflection yoke until it touches the funnel side of the CRT.
4. Adjust center of screen to green, with red and blue on the sides, using the pair of purity magnets.
5. Switch the color bar generator from the green raster pattern to the crosshatch pattern.
6. Combine red and blue of the 3 color crosshatch pattern on the center of the screen by adjusting the pair of 4 pole magnets.
7. Combine red/blue (magenta) and green by adjusting the pair of 6 pole magnets.
8. Adjust the crosshatch pattern to change to white by repeating steps 6 and 7.

5-2: PURITY

NOTE

Adjust after performing adjustments in section 5-1.

1. Receive the green raster pattern from the color bar generator.
2. Adjust the pair of purity magnets to center the color on the screen.
Adjust the pair of purity magnets so the color at the ends are equally wide.
3. Move the deflection yoke backward (to neck side) slowly, and stop it at the position when the whole screen is green.
4. Confirm red and blue colors.
5. Adjust the slant of the deflection yoke while watching the screen, then tighten the fixing screw.

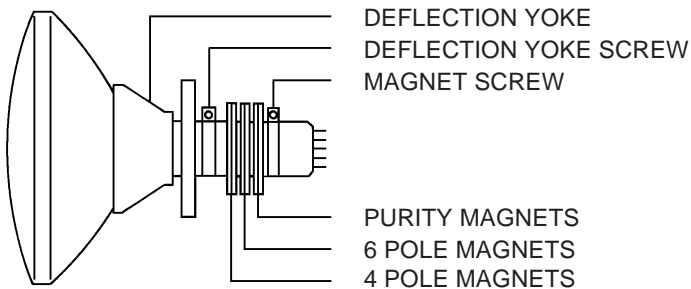

Fig. 5-1

5-3: STATIC CONVERGENCE

NOTE

Adjust after performing adjustments in section 5-2.

1. Receive the crosshatch pattern from the color bar generator.
2. Combine red and blue of the 3 color crosshatch pattern on the center of the screen by adjusting the pair of 4 pole magnets.
3. Combine red/blue (magenta) and green by adjusting the pair of 6 pole magnets.

5-4: DYNAMIC CONVERGENCE

NOTE

Adjust after performing adjustments in section 5-3.

1. Adjust the differences around the screen by moving the deflection yoke upward/downward and right/left. **(Refer to Fig. 5-2-a)**
2. Insert three wedges between the deflection yoke and CRT funnel to fix the deflection yoke. **(Refer to Fig. 5-2-b)**

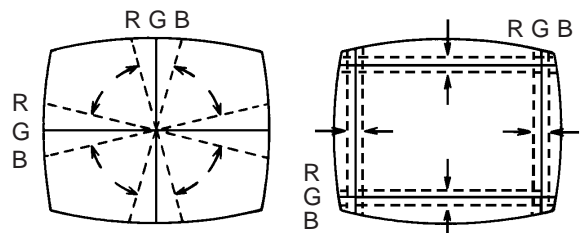

UPWARD/DOWNWARD SLANT RIGHT/LEFT SLANT

Fig. 5-2-a

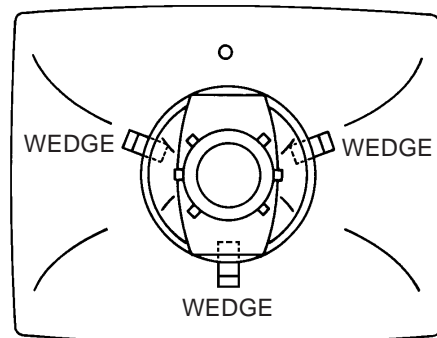

WEDGE POSITION

Fig. 5-2-b

MAJOR COMPONENTS LOCATION GUIDE

(TV SECTION)

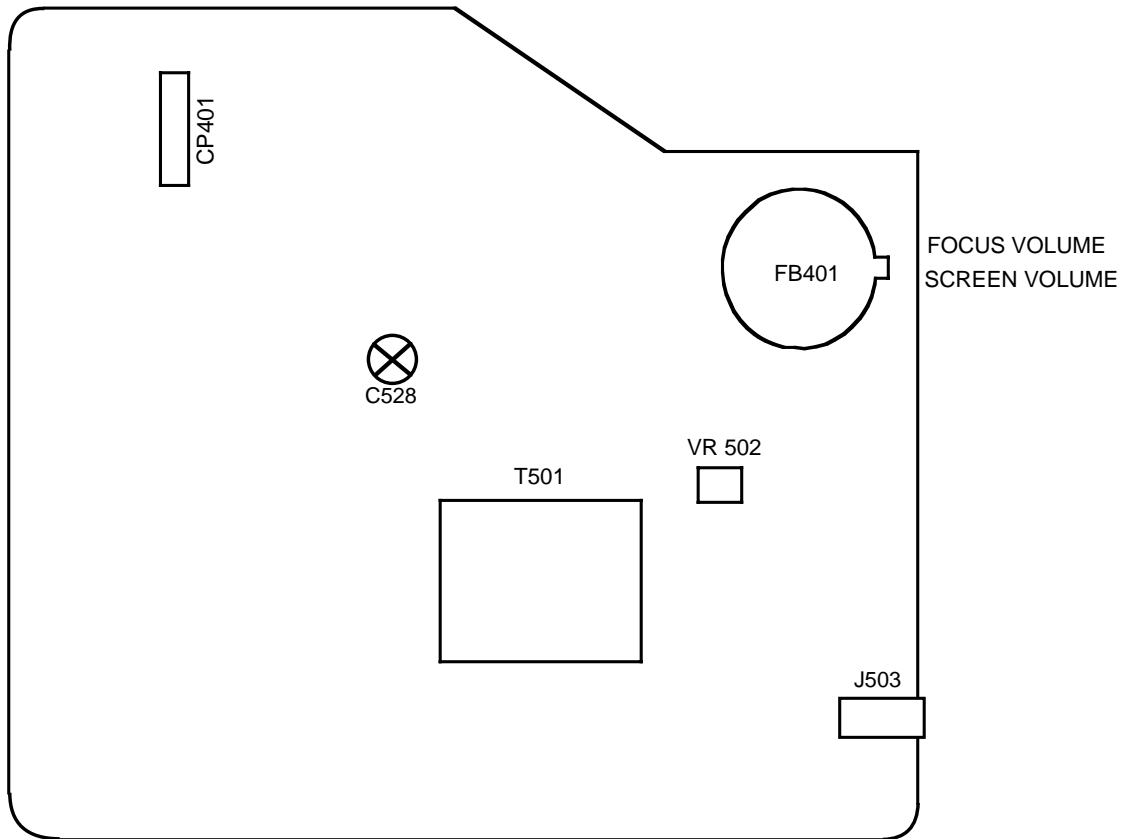

MAIN

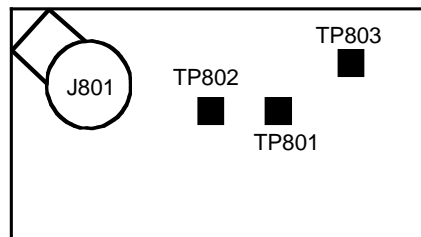

CRT

MAJOR COMPONENTS LOCATION GUIDE (VCR SECTION)

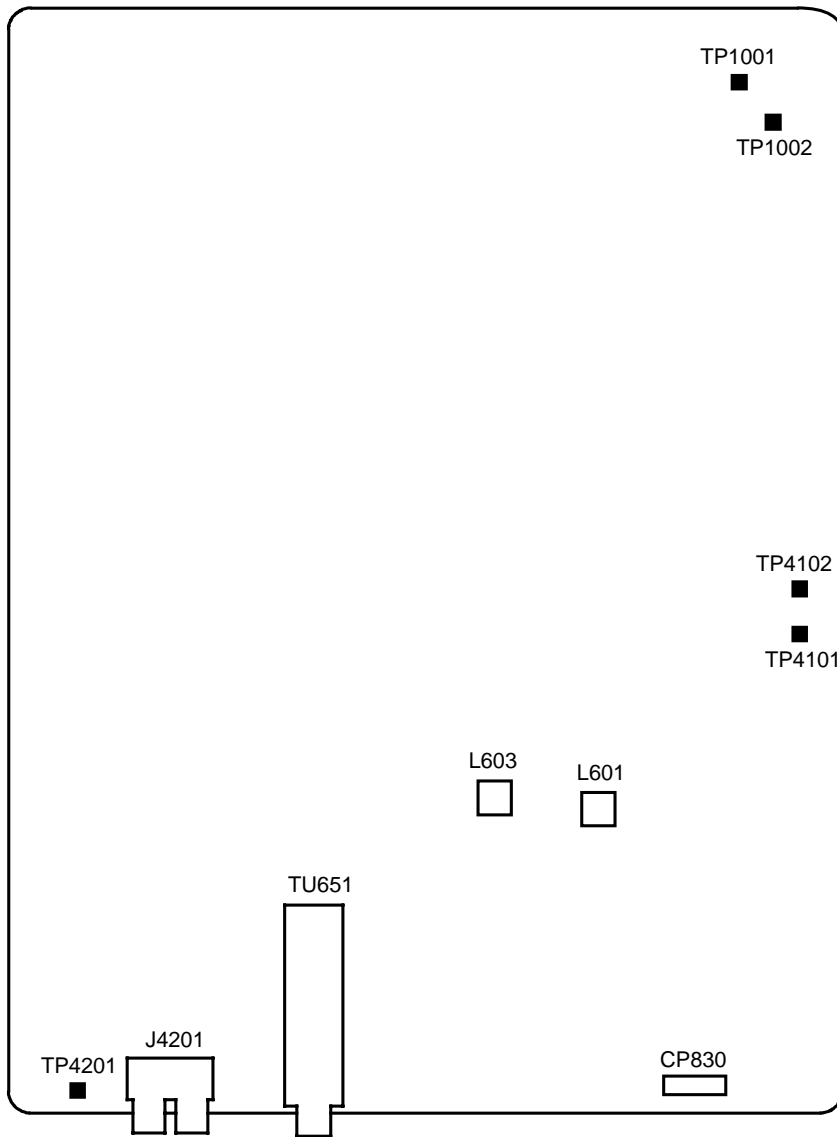

SYSCON

TV BLOCK DIAGRAM

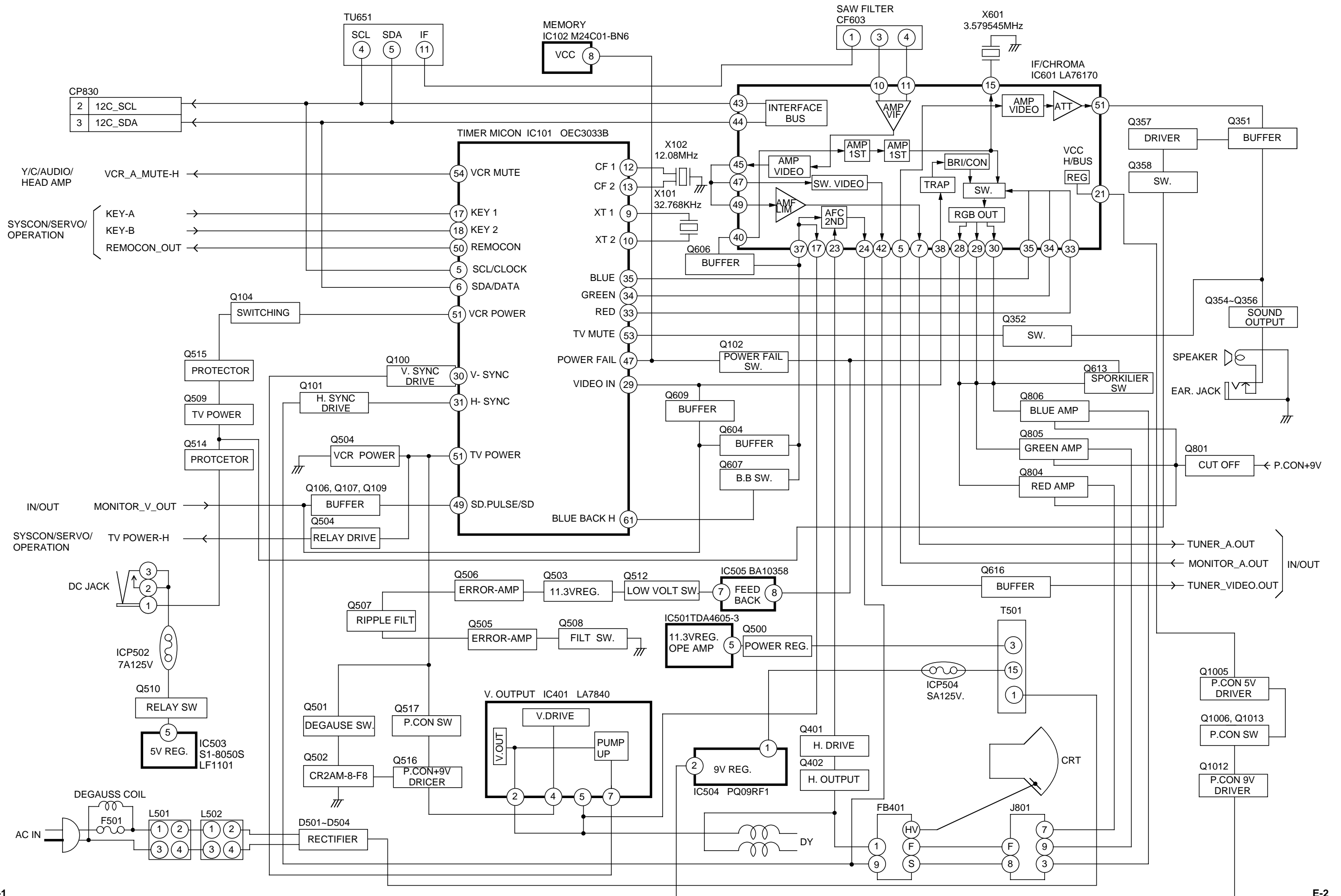

Y/C/AUDIO/HEAD AMP BLOCK DIAGRAM

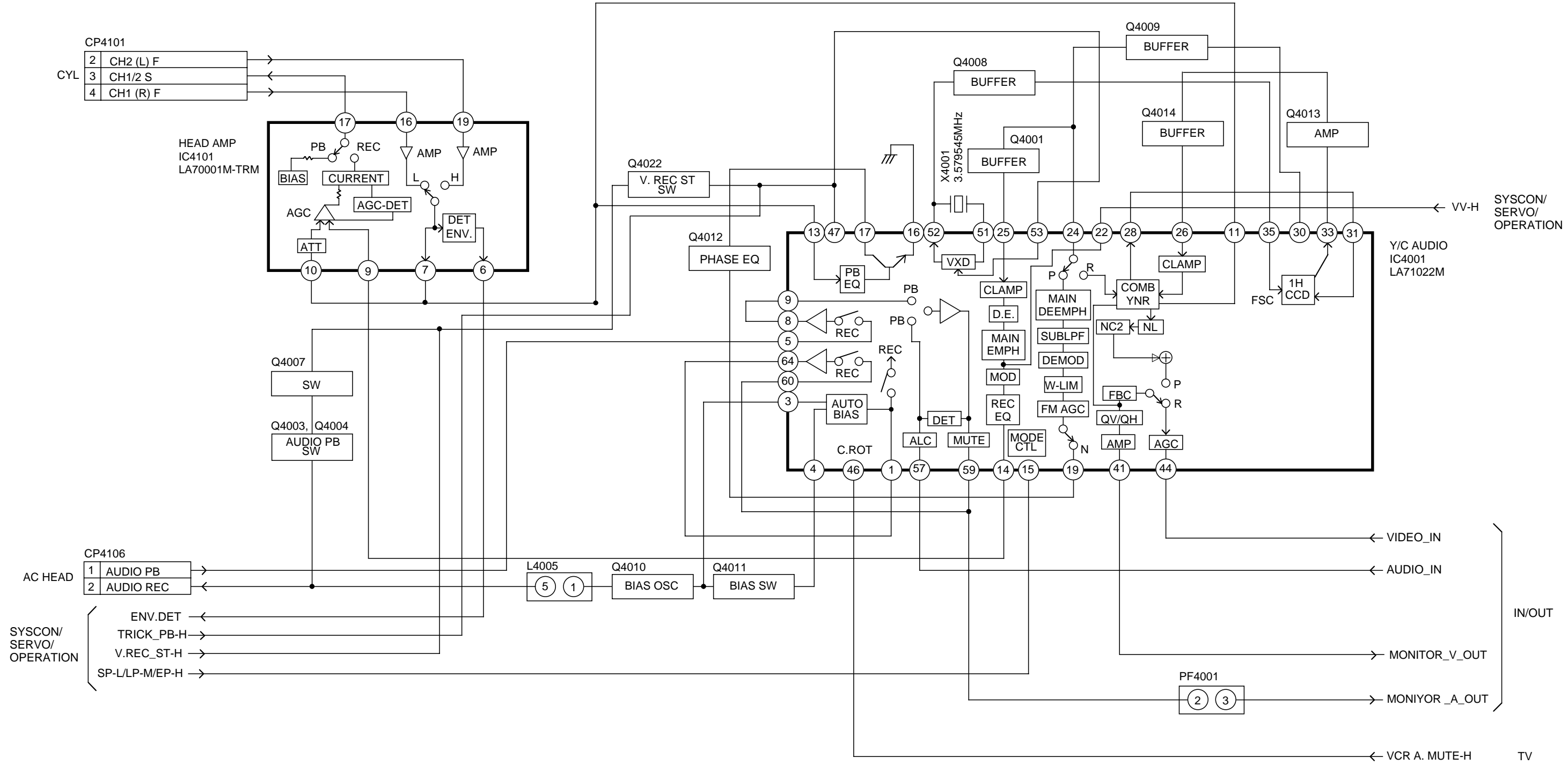

SYSCON/SERVO/OPERATION BLOCK DIAGRAM

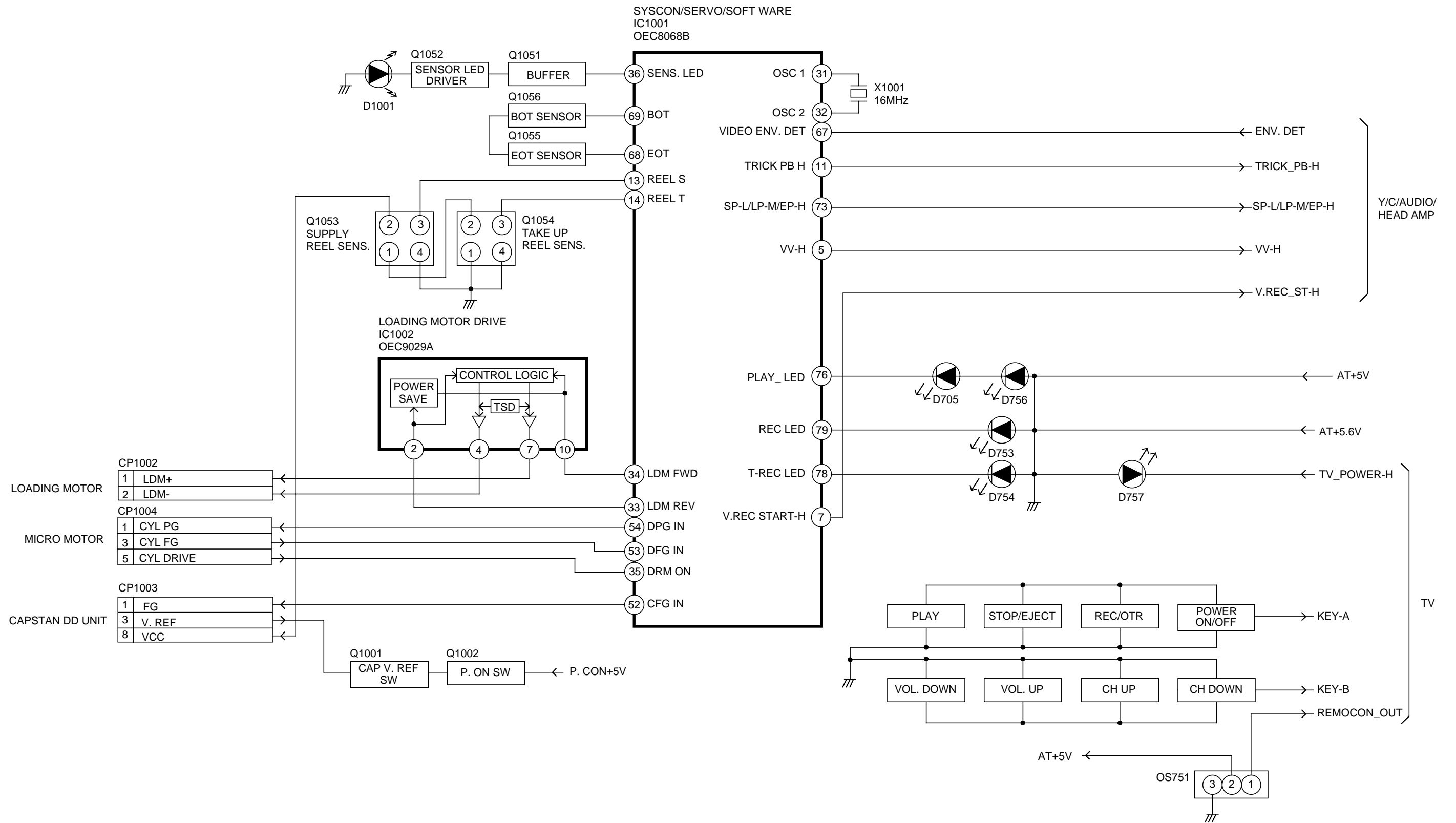

IN/OUT BLOCK DIAGRAM

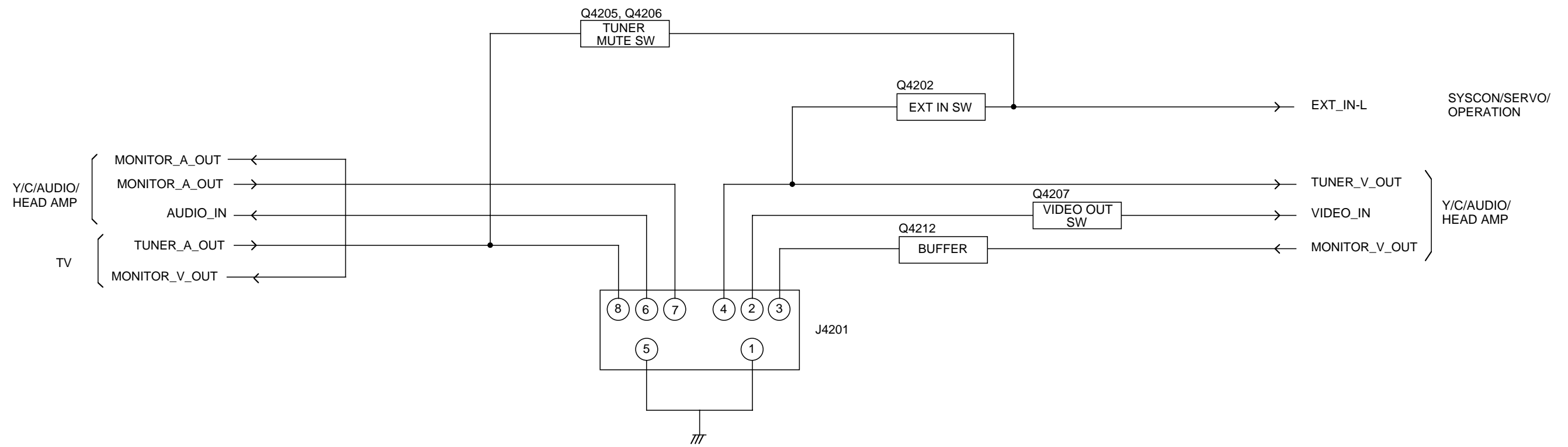

PRINTED CIRCUIT BOARDS MAIN/CRT SOLDER SIDE

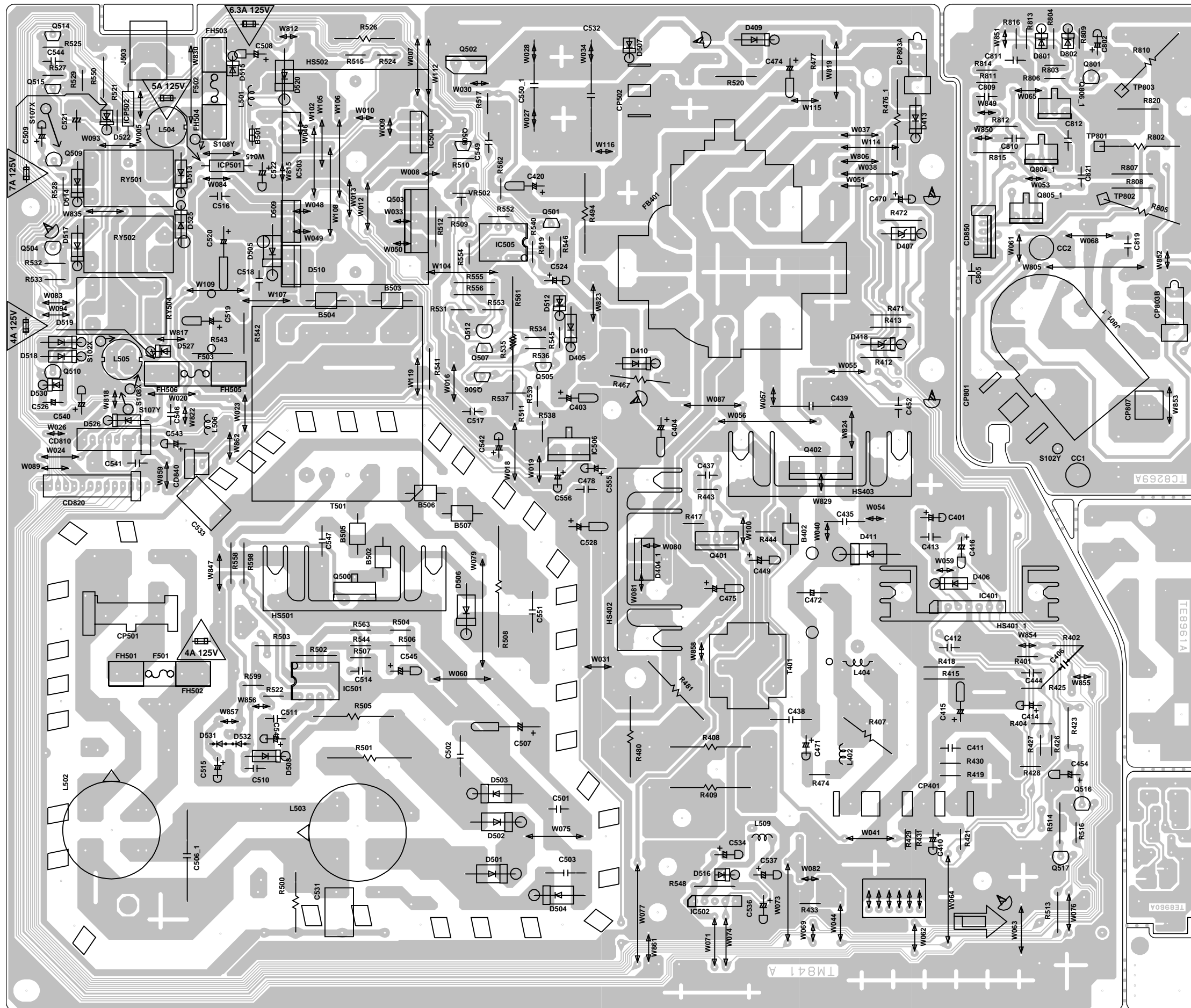

PRINTED CIRCUIT BOARDS
SYSCON (CHIP MOUNTED PARTS)
SOLDER SIDE

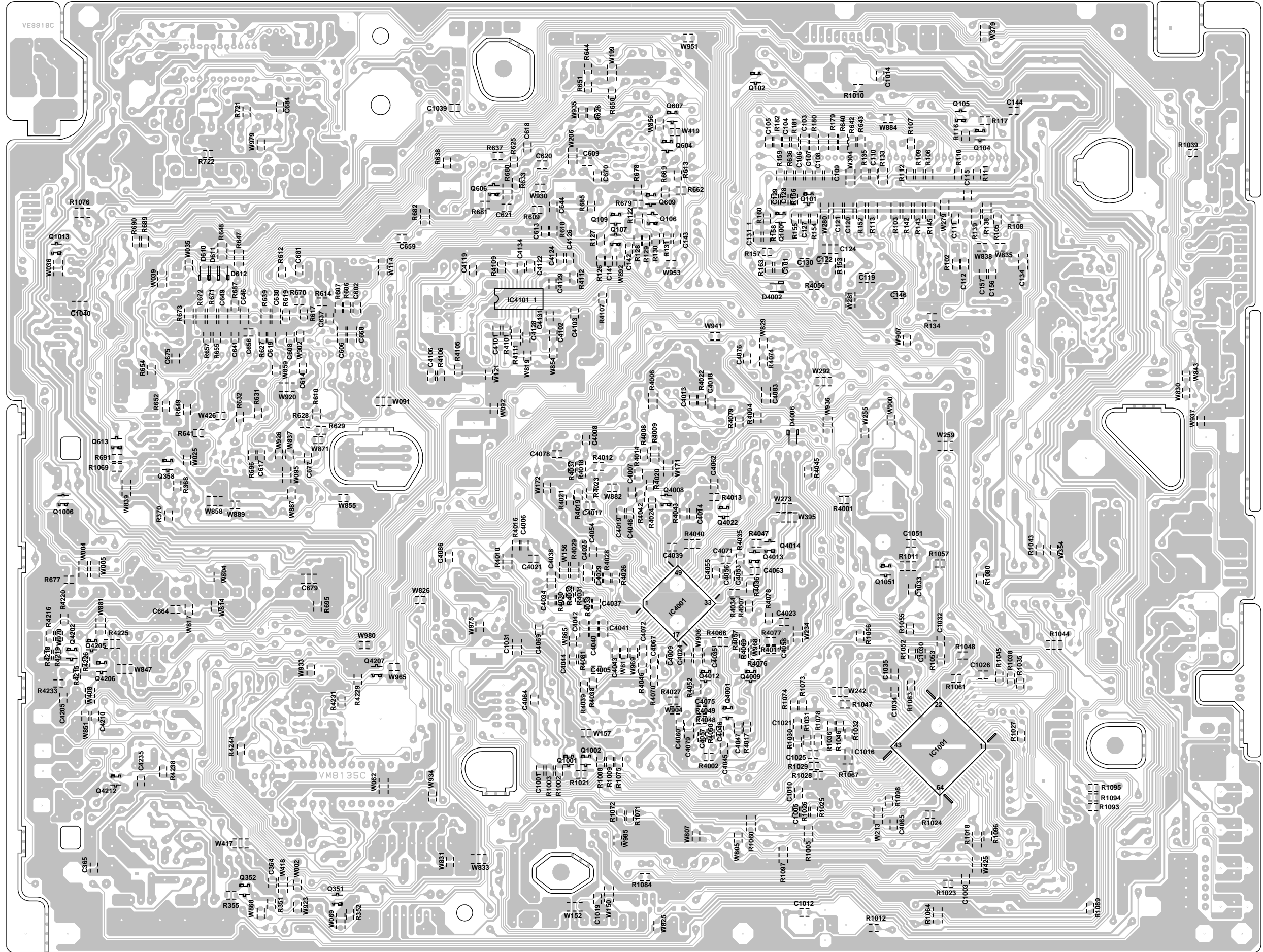

PRINTED CIRCUIT BOARDS

OPERATION SOLDER SIDE

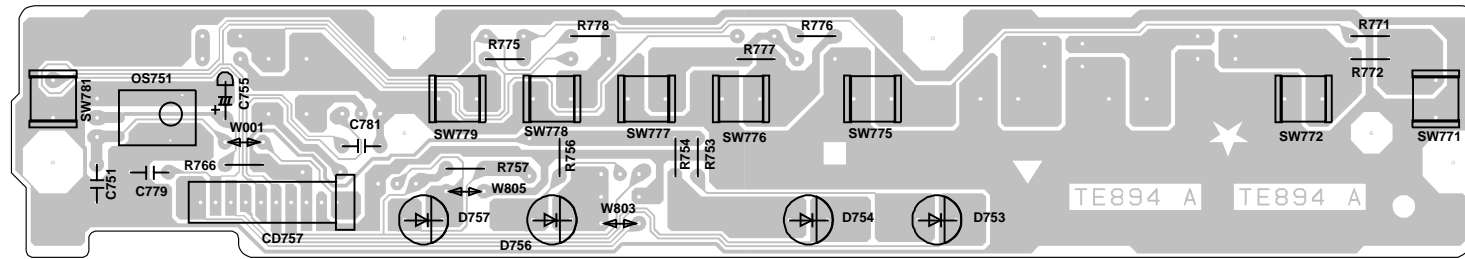

TIMER MICON SCHEMATIC DIAGRAM

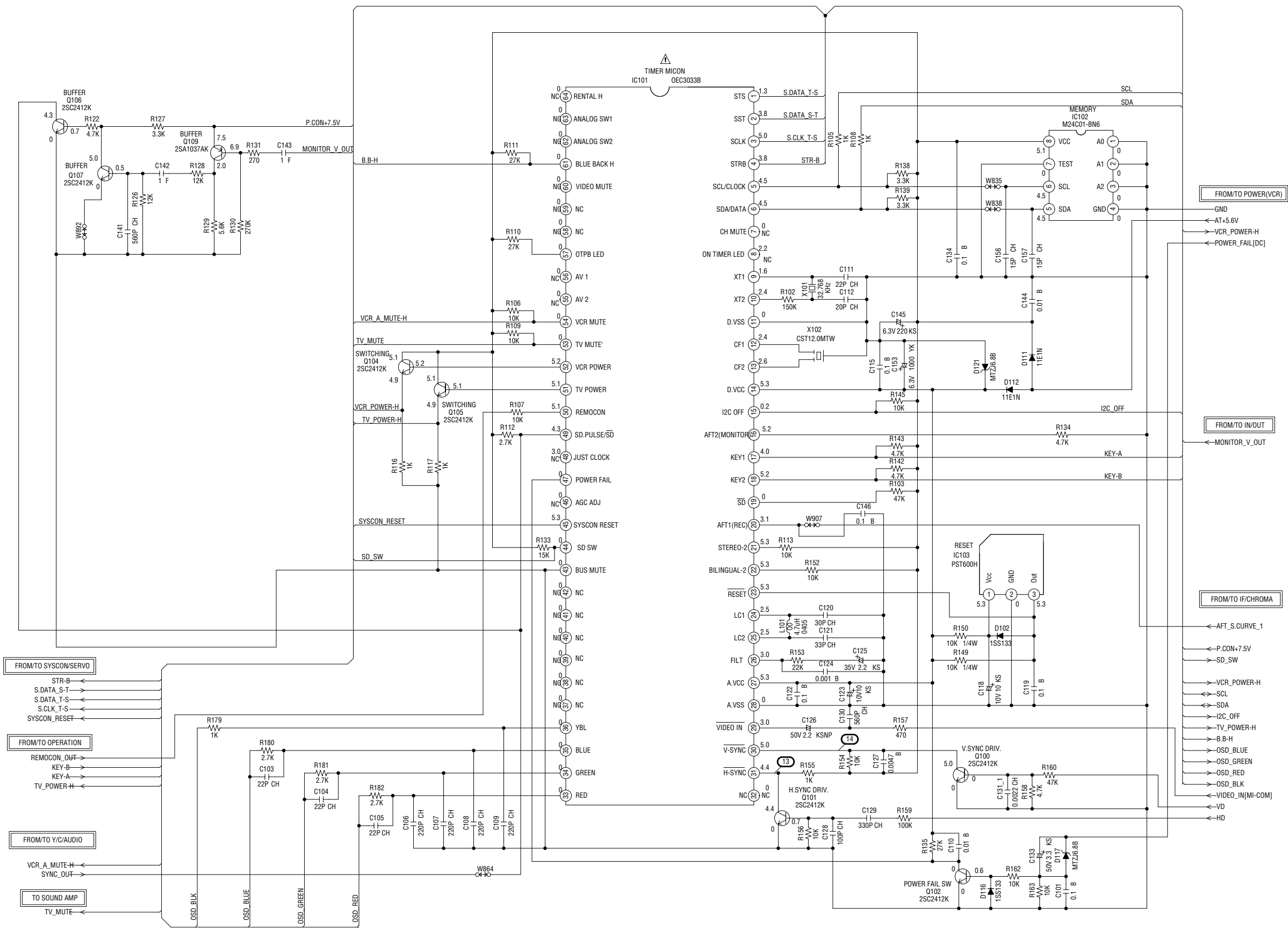

FROM/TO SYSCON/SERVO

STR-B
S.DATA_S-T
S.DATA_T-S
S.CLK_T-S
SYSCON_RESET

FROM/TO OPERATION

REMOCON_OUT
KEY-B
KEY-A
TV_POWER-H

FROM/TO Y/C/AUDIO

VCR_A_MUTE-H
SYNC_OUT

TO SOUND AMP

TV_MUTE

FROM/TO POWER(VCR)

GND
AT+5.6V
VCR_POWER-H
POWER_FAIL[DC]

FROM/TO IN/OUT

MONITOR_V_OUT

FROM/TO IF/CHROMA

AFT_S_CURVE_1

P.CON+7.5V
SD_SW
VCR_POWER-H
SCL
SDA
I2C_OFF
TV_POWER-H
B.B-H
OSD_BLUE
OSD_GREEN
OSD_RED
VIDEO_IN[MI-COM]
VD
HD

NOTE: THIS SCHEMATIC DIAGRAM IS THE LATEST AT THE TIME OF PRINTING AND SUBJECT TO CHANGE WITHOUT NOTICE.

CAUTION: SINCE THESE PARTS MARKED BY ARE CRITICAL FOR SAFETY, USE ONES DESCRIBED IN PARTS LIST ONLY.

ATTENTION: LES PIÈCES RÉPARÉES PAR UN ÉTANT DANGEREUSES AU POINT DE VUE SÉCURITÉ, N'UTILISER QUE CELLES DÉCRITES DANS LA NOMENCLATURE DES PIÈCES.

NOTE: THE DC VOLTAGE AT EACH PART WAS MEASURED WITH THE DIGITAL TESTER WHEN THE COLOR BROADCAST WAS RECEIVED IN GOOD CONDITION AND PICTURE IS NORMAL.

PCB010
VM8135

IF/CHROMA SCHEMATIC DIAGRAM

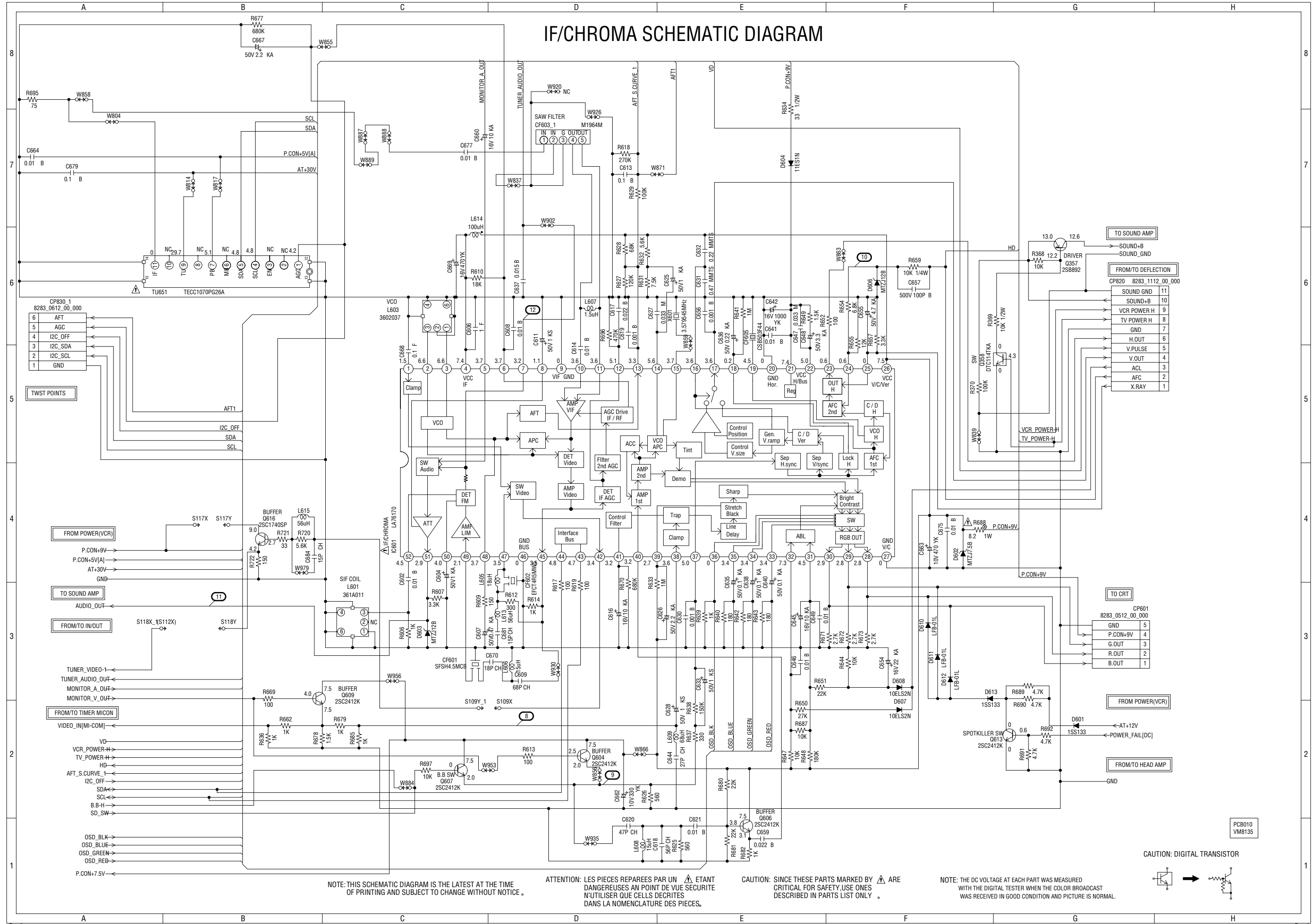

NOTE: THIS SCHEMATIC DIAGRAM IS THE LATEST AT THE TIME OF PRINTING AND SUBJECT TO CHANGE WITHOUT NOTICE.

ATTENTION: LES PIÈCES RÉPARÉES PAR UN ÉTANT DANGEREUSES AN POINT DE VUE SECURITE N'UTILISER QUE CELLES DÉCRITES DANS LA NOMENCLATURE DES PIÈCES.

CAUTION: SINCE THESE PARTS MARKED BY ARE CRITICAL FOR SAFETY, USE ONES DESCRIBED IN PARTS LIST ONLY.

NOTE: THE DC VOLTAGE AT EACH PART WAS MEASURED WITH THE DIGITAL TESTER WHEN THE COLOR BROADCAST WAS RECEIVED IN GOOD CONDITION AND PICTURE IS NORMAL.

CAUTION: DIGITAL TRANSISTOR

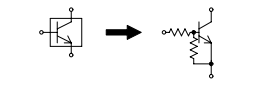

SOUND AMP SCHEMATIC DIAGRAM

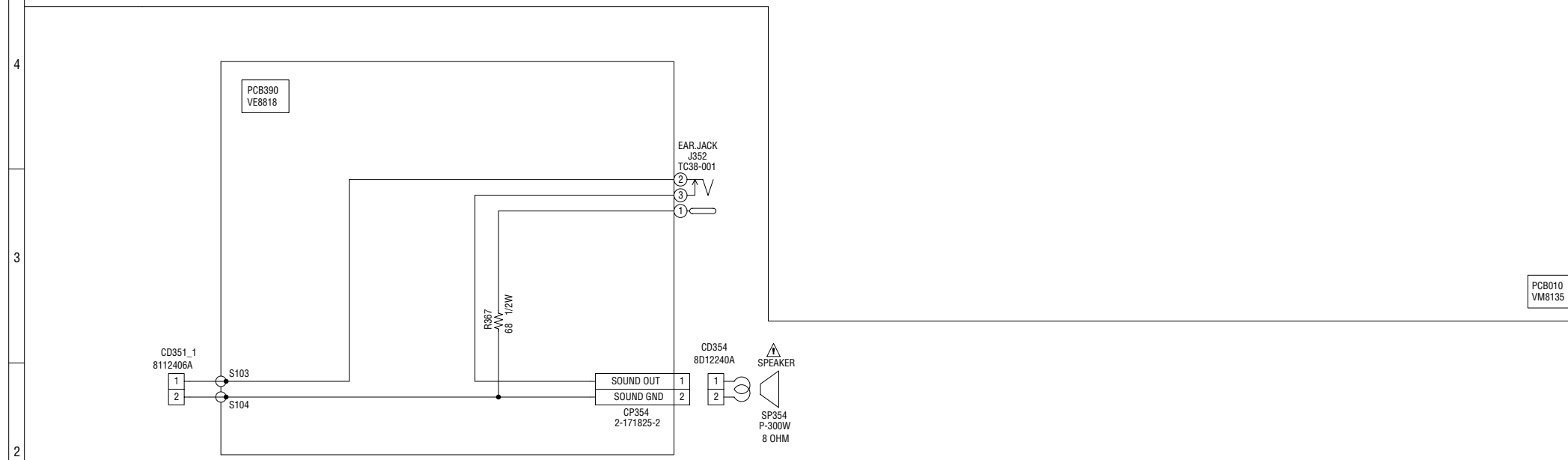
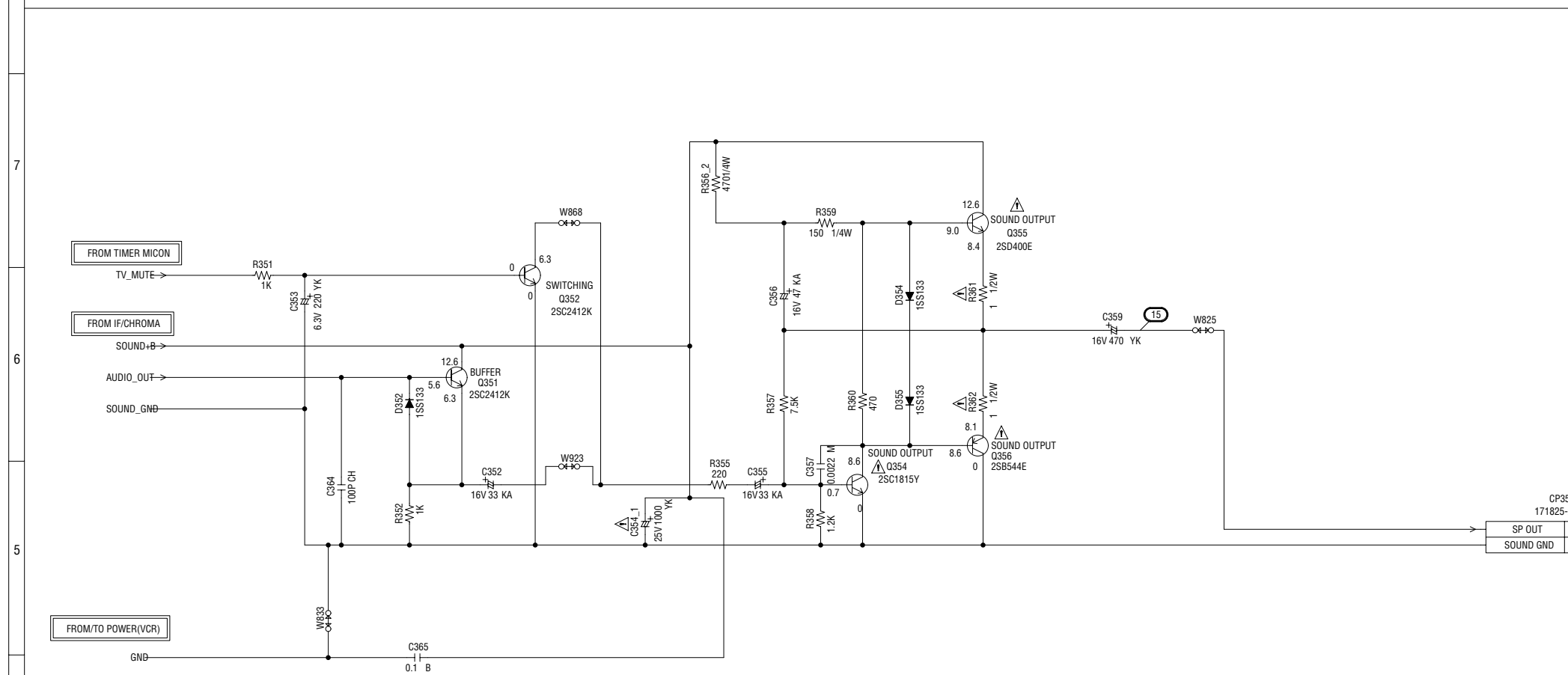

CAUTION: SINCE THESE PARTS MARKED BY ARE CRITICAL FOR SAFETY, USE ONES DESCRIBED IN PARTS LIST ONLY .

ATTENTION: LES PIECES REPARÉES PAR UN ÉTANT DANGEREUSES AN POINT DE VUE SECURITE N'UTILISER QUE CELLS DECRITES DANS LA NOMENCLATURE DES PIECES.

NOTE: THIS SCHEMATIC DIAGRAM IS THE LATEST AT THE TIME OF PRINTING AND SUBJECT TO CHANGE WITHOUT NOTICE .

NOTE: THE DC VOLTAGE AT EACH PART WAS MEASURED WITH THE DIGITAL TESTER WHEN THE COLOR BROADCAST WAS RECEIVED IN GOOD CONDITION AND PICTURE IS NORMAL.

DEFLECTION SCHEMATIC DIAGRAM

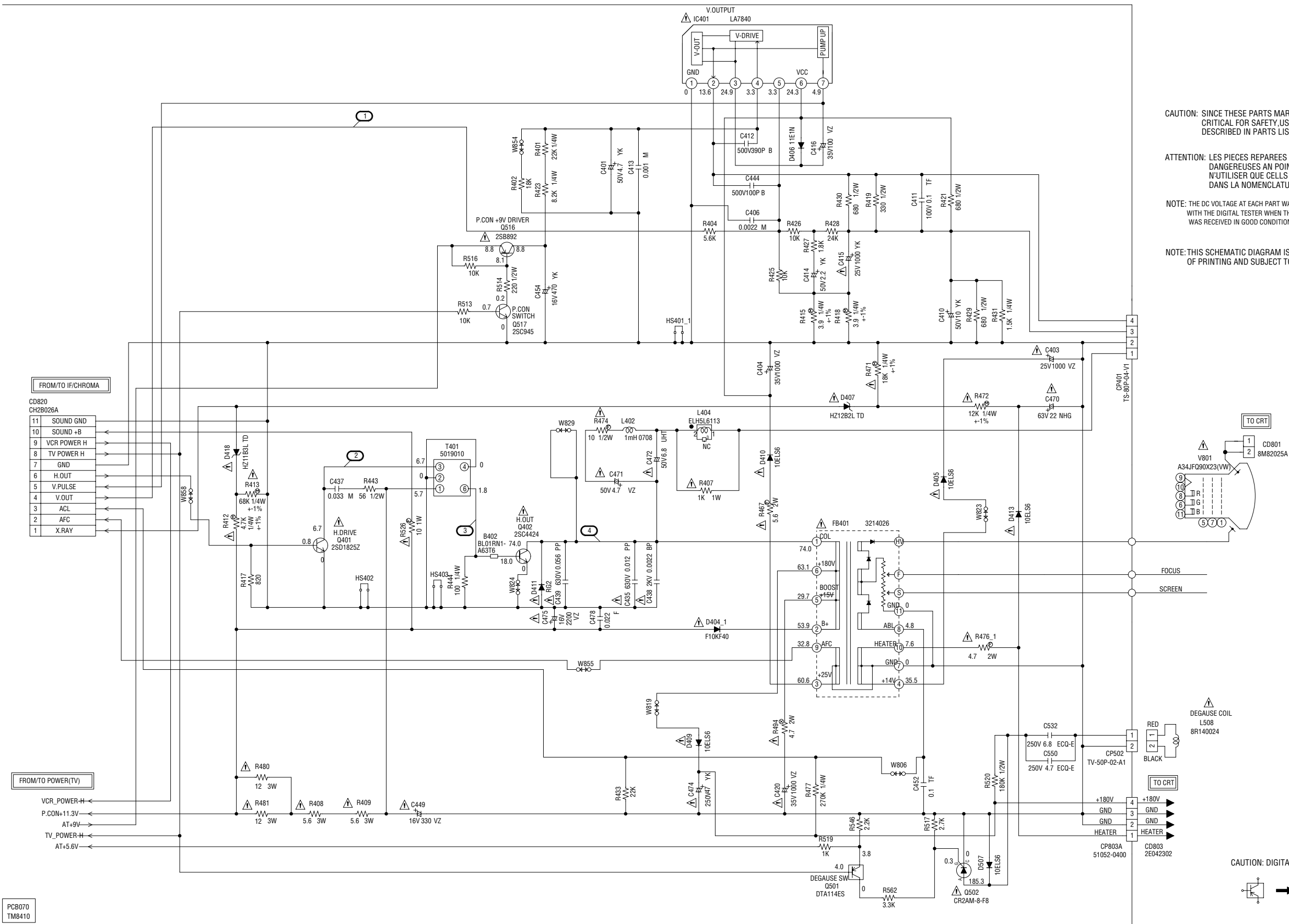

FROM/TO IF/CHROMA

11	SOUND GND
10	SOUND +B
9	VCR POWER H
8	TV POWER H
7	GND
6	H.OUT
5	V.PULSE
4	V.OUT
3	ACL
2	AFC
1	X.RAY

FROM/TO POWER(TV)

VCR_POWER-H
P.CON+11.3V
AT+9V
TV_POWER-H
AT+5.6V

PCB070
TM8410

CAUTION: SINCE THESE PARTS MARKED BY ARE CRITICAL FOR SAFETY, USE ONES DESCRIBED IN PARTS LIST ONLY.

ATTENTION: LES PIECES REPARÉES PAR UN ÉTANT DANGEREUSES AN POINT DE VUE SECURITE N'UTILISER QUE CELLS DECRITES DANS LA NOMENCLATURE DES PIECES.

NOTE: THE DC VOLTAGE AT EACH PART WAS MEASURED WITH THE DIGITAL TESTER WHEN THE COLOR BROADCAST WAS RECEIVED IN GOOD CONDITION AND PICTURE IS NORMAL.

NOTE: THIS SCHEMATIC DIAGRAM IS THE LATEST AT THE TIME OF PRINTING AND SUBJECT TO CHANGE WITHOUT NOTICE.

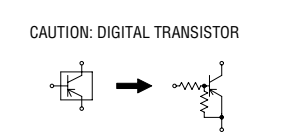
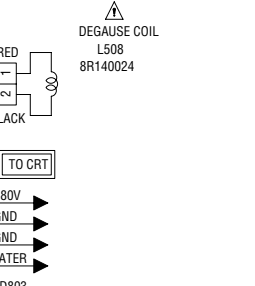
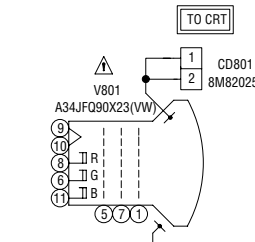

CRT SCHEMATIC DIAGRAM

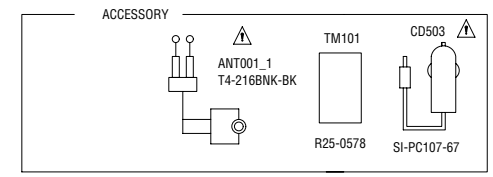
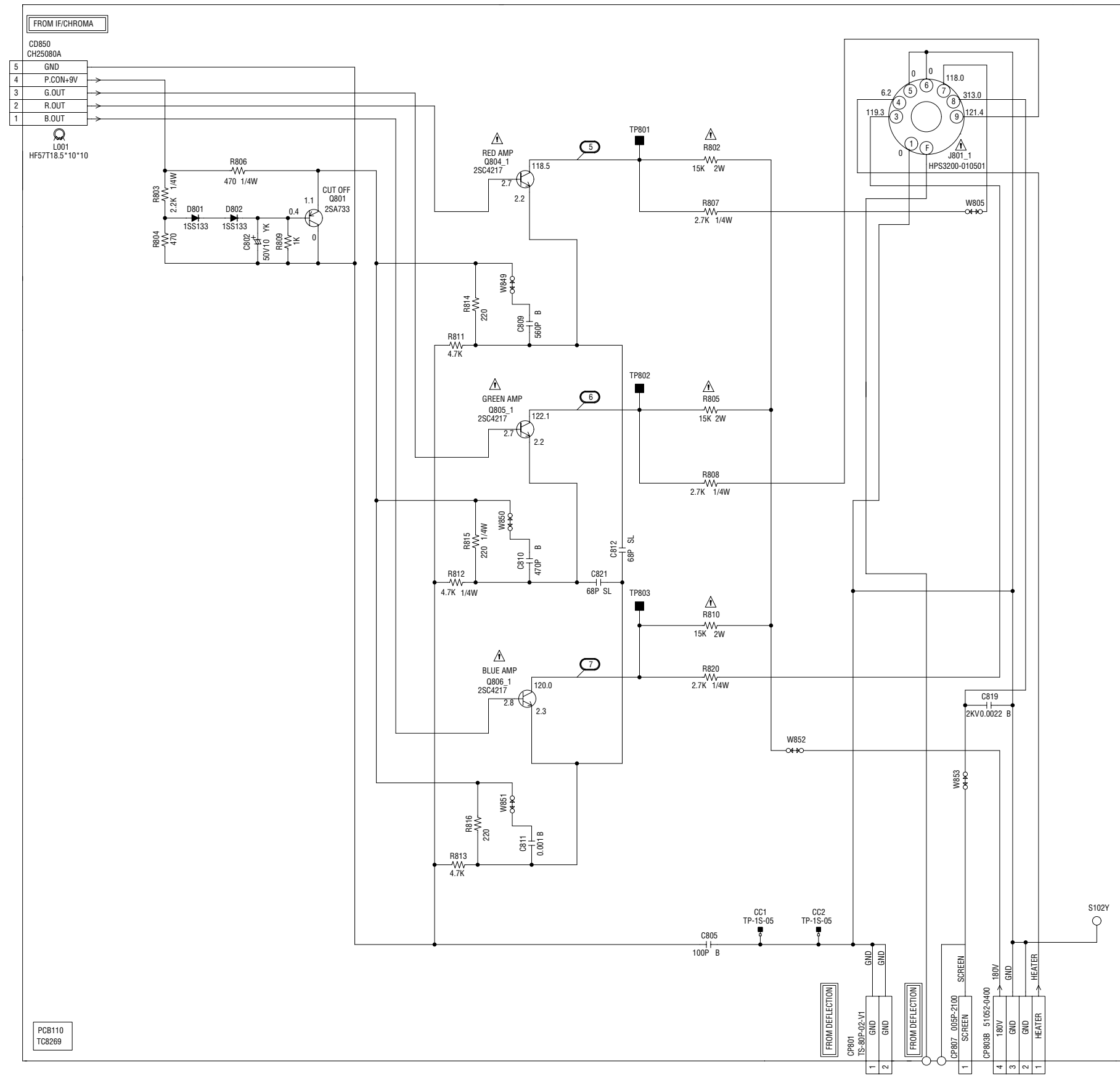

NOTE: THIS SCHEMATIC DIAGRAM IS THE LATEST AT THE TIME OF PRINTING AND SUBJECT TO CHANGE WITHOUT NOTICE.

CAUTION: SINCE THESE PARTS MARKED BY ARE CRITICAL FOR SAFETY, USE ONES DESCRIBED IN PARTS LIST ONLY.

ATTENTION: LES PIÈCES RÉPARÉES PAR UN ÉTANT DANGEREUSES À UN POINT DE VUE SÉCURITÉ, N'UTILISER QUE CELLES DÉCRITES DANS LA NOMENCLATURE DES PIÈCES.

NOTE: THE DC VOLTAGE AT EACH PART WAS MEASURED WITH THE DIGITAL TESTER WHEN THE COLOR BROADCAST WAS RECEIVED IN GOOD CONDITION AND PICTURE IS NORMAL.

POWER(TV) SCHEMATIC DIAGRAM

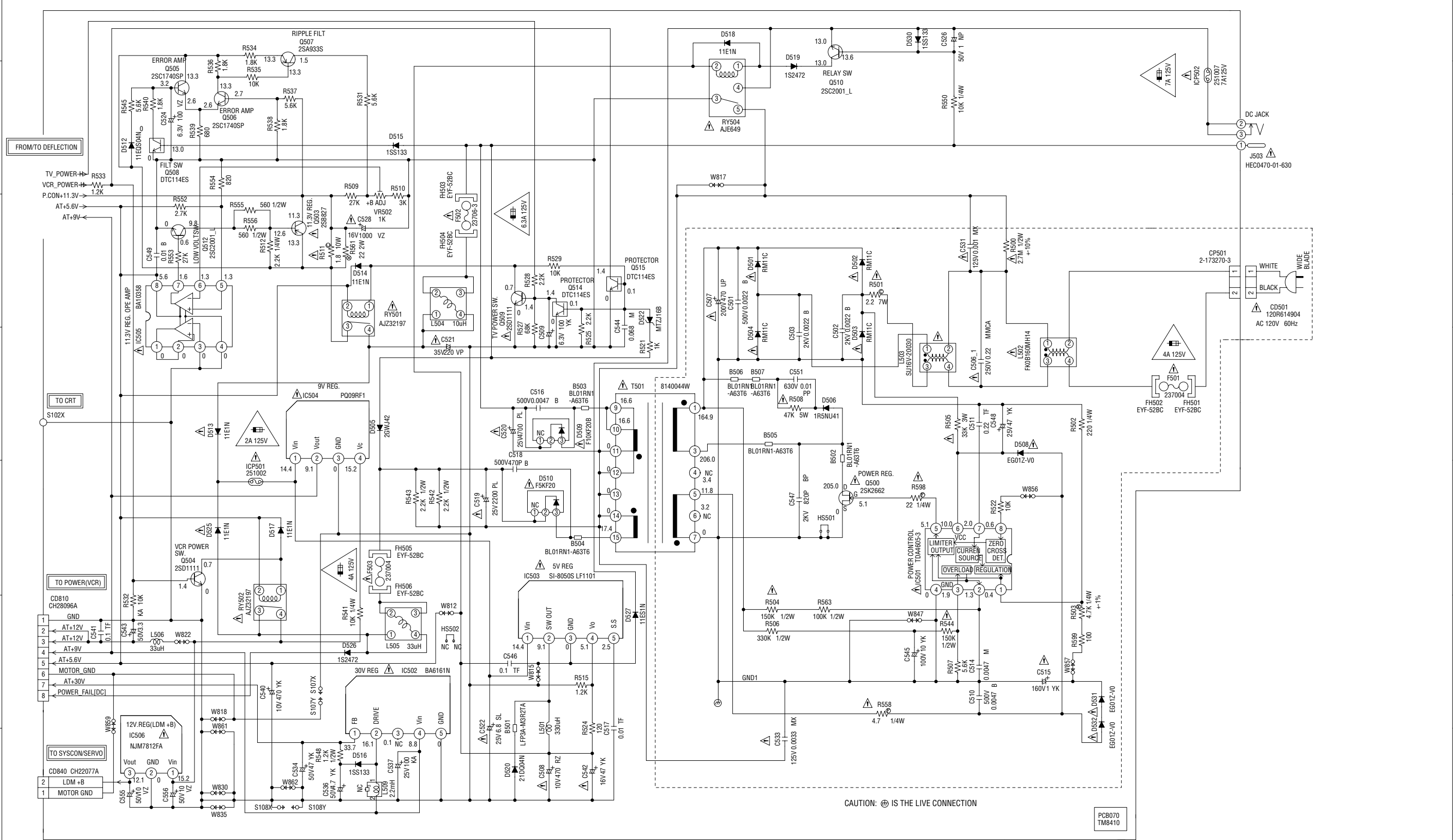

CAUTION: ⊕ IS THE LIVE CONNECTION

PCB070
TM8410

CAUTION: FOR CONTINUED PROTECTION AGAINST FIRE HAZARD, REPLACE ONLY WITH THE SAME TYPE FUSE 4A 125V (F501, F503), 6.3A 125V (F502), 2A 125V (ICP501), AND 7A 125V (ICP502).

ATTENTION: POUR UNE PROTECTION CONTINUE LES RISQUES D'INCENDIE N'UTILISER QUE DES FUSIBLES DE MEME TYPE 4A 125V (F501, F503), 6.3A 125V (F502), 2A 125V (ICP501), ET 7A 125V (ICP502).

CAUTION: DIGITAL TRANSISTOR

CAUTION: SINCE THESE PARTS MARKED BY ⊕ ARE CRITICAL FOR SAFETY, USE ONES DESCRIBED IN PARTS LIST ONLY.

ATTENTION: LES PIECES REPARÉES PAR UN ⊕ ÉTANT DANGEREUSES AU POINT DE VUE SECURITE N'UTILISER QUE CELLES DECRITES DANS LA NOMENCLATURE DES PIECES.

NOTE: THIS SCHEMATIC DIAGRAM IS THE LATEST AT THE TIME OF PRINTING AND SUBJECT TO CHANGE WITHOUT NOTICE.

NOTE: THE DC VOLTAGE AT EACH PART WAS MEASURED WITH THE DIGITAL TESTER WHEN THE COLOR BROADCAST WAS RECEIVED IN GOOD CONDITION AND PICTURE IS NORMAL.

OPERATION(2) SCHEMATIC DIAGRAM

FROM/TO OPERATION(1)

CD757	CH2A012A
1	REMOCON OUT
2	GND
3	AT 5V
4	P.C 5V/TV PWR-H
5	NC
6	KEY-A
7	T-REC LED
8	REC LED
9	KEY-B
10	PLAY LED

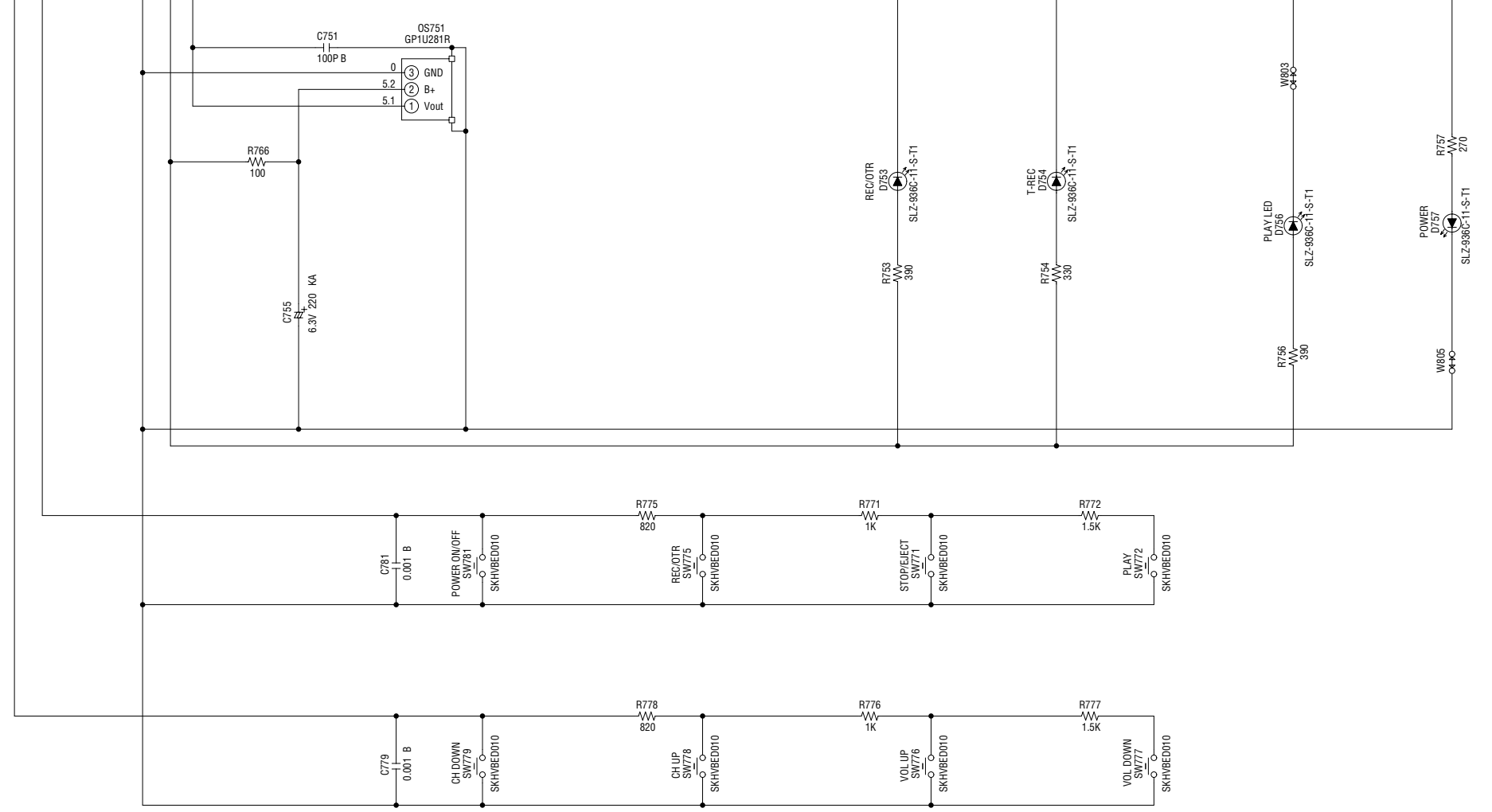

NOTE: THIS SCHEMATIC DIAGRAM IS THE LATEST AT THE TIME OF PRINTING AND SUBJECT TO CHANGE WITHOUT NOTICE.

PCB030
TE8940

Y/C/AUDIO SCHEMATIC DIAGRAM

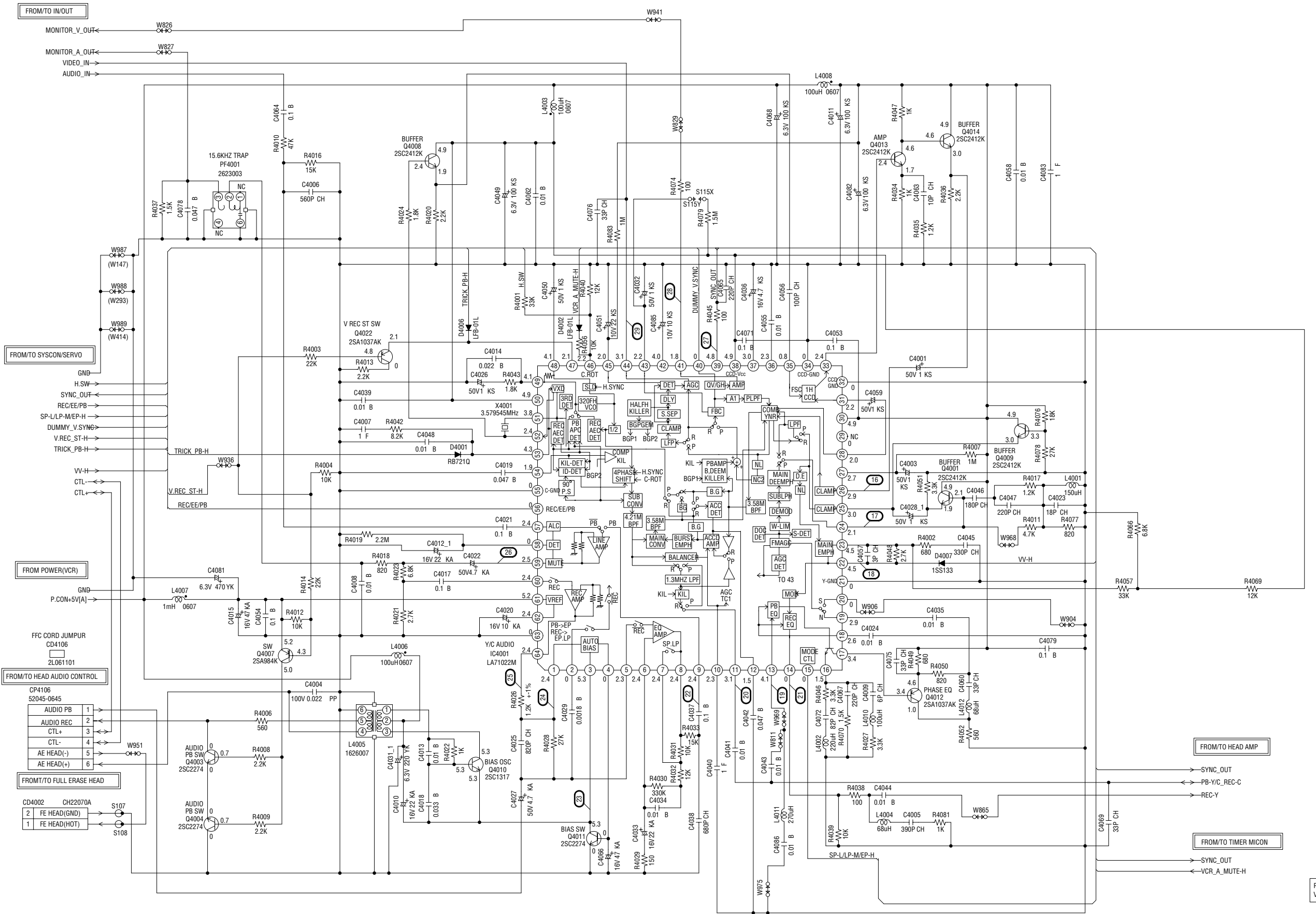

FROM/TO SYS/CON/SERVO

GND

H.S.W

SYNC_OUT

REC/EE/PB

SP-L/LP-M/EP-H

DUMMY_V.SYNG

V.REC.ST-H

TRICK_PB-H

VV-H

CTL

CTL

FROM POWER(VCR)

GND

P.CON+5V[A]

FROM/TO HEAD AUDIO CONTROL

CP4106
52045-0645

AUDIO PB	1
AUDIO REC	2
CTL+	3
CTL-	4
AE HEAD(-)	5
AE HEAD(+)	6

W951

FROM/TO FULL ERASE HEAD

CD4002	CH22070A
2	FE HEAD(GND)
1	FE HEAD(HOT)

S107

S108

FROM/TO HEAD AMP

SYNC_OUT

PB-Y/C_REC-C

REC-Y

FROM/TO TIMER MICON

SYNC_OUT

VCR_A_MUTE-H

NOTE: THE DC VOLTAGE AT EACH PART WAS MEASURED WITH THE DIGITAL TESTER DURING PLAYBACK.

NOTE: THIS SCHEMATIC DIAGRAM IS THE LATEST AT THE TIME OF PRINTING AND SUBJECT TO CHANGE WITHOUT NOTICE.

PCB010
VM8135

HEAD AMP SCHEMATIC DIAGRAM

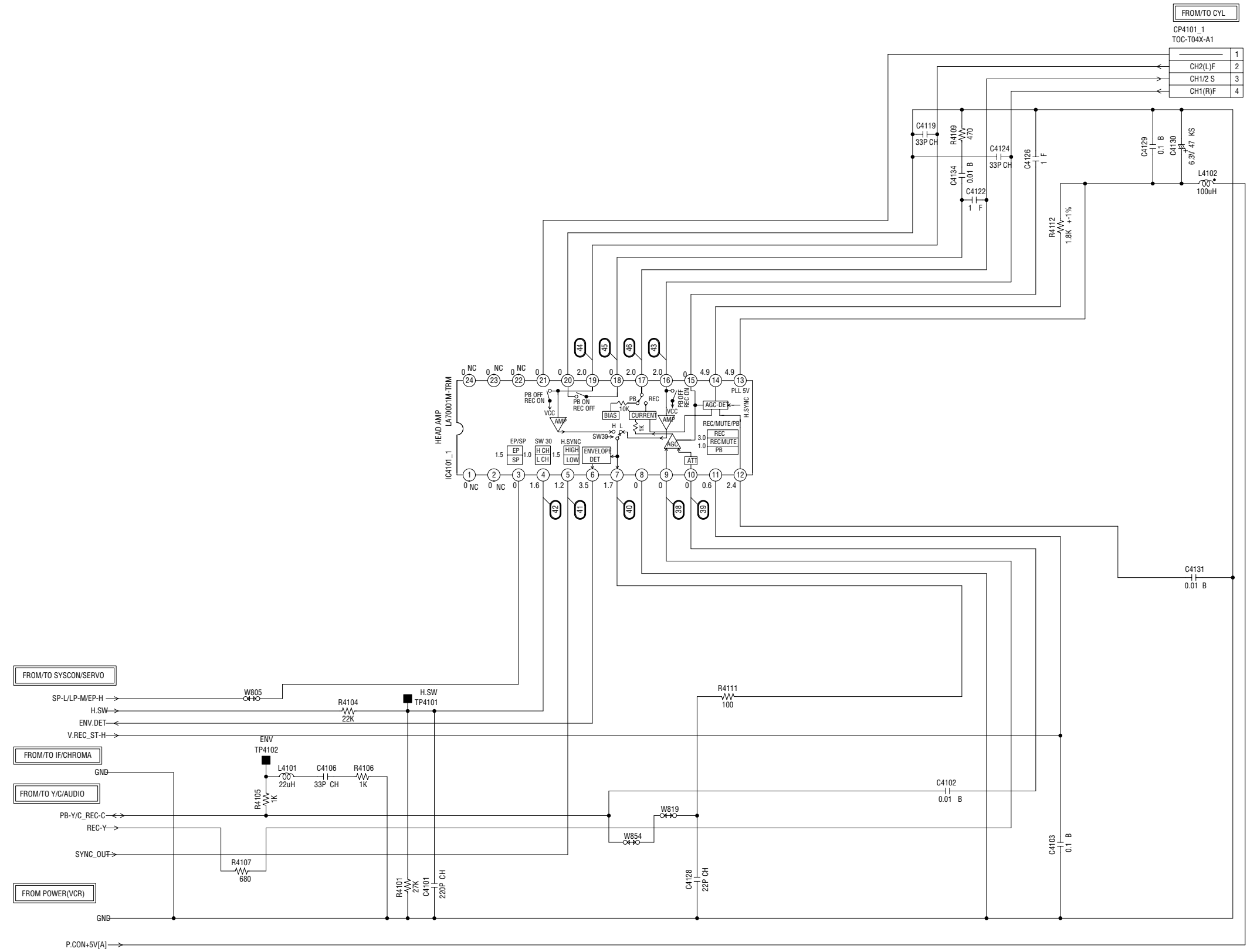

NOTE: THE DC VOLTAGE AT EACH PART WAS MEASURED WITH THE DIGITAL TESTER DURING PLAYBACK.

NOTE: THIS SCHEMATIC DIAGRAM IS THE LATEST AT THE TIME OF PRINTING AND SUBJECT TO CHANGE WITHOUT NOTICE.

PC8010
VM8135

IN/OUT SCHEMATIC DIAGRAM

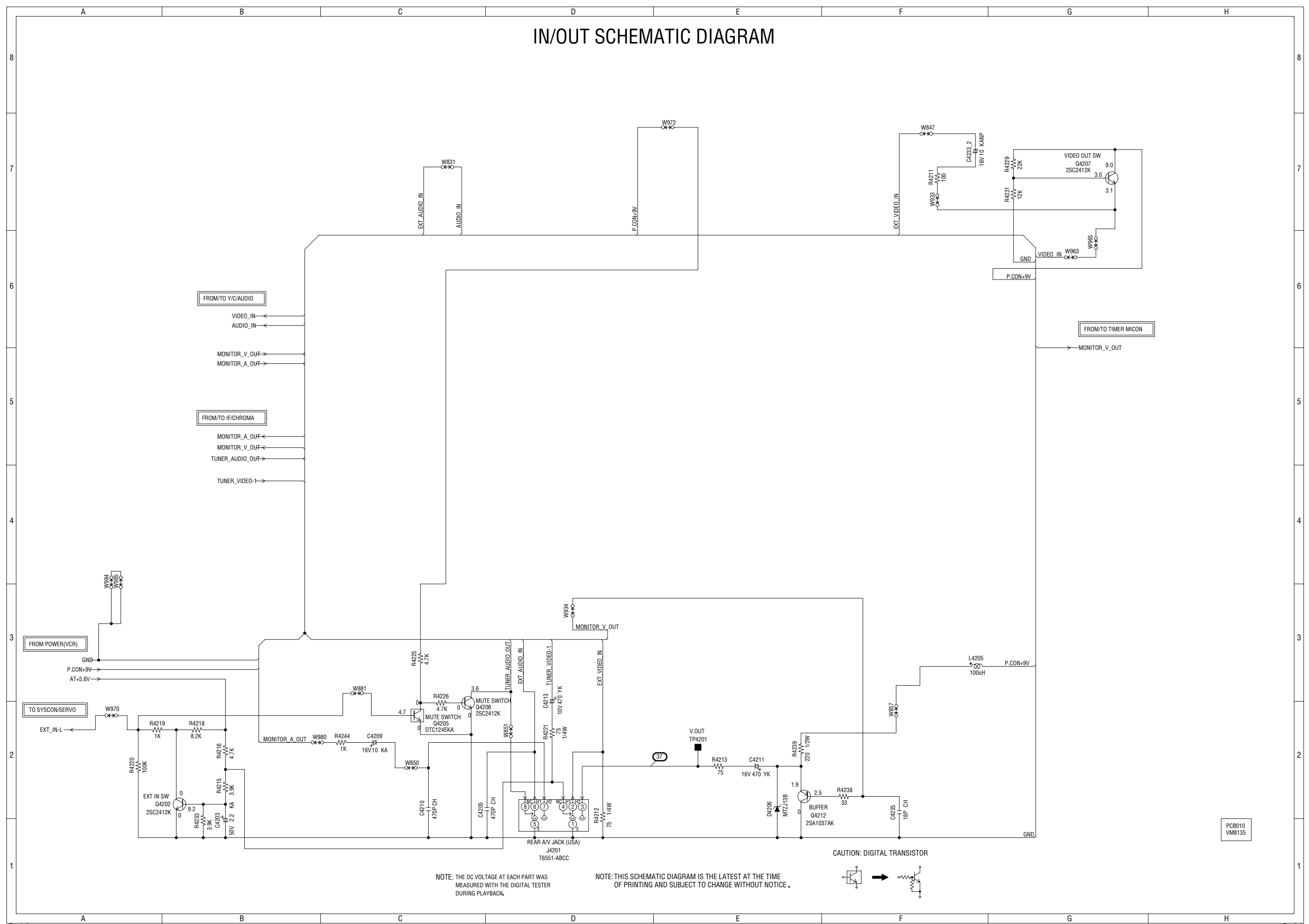

NOTE: THE DC VOLTAGE AT EACH PART WAS MEASURED WITH THE DIGITAL TESTER DURING PLAYBACK.

NOTE: THIS SCHEMATIC DIAGRAM IS THE LATEST AT THE TIME OF PRINTING AND SUBJECT TO CHANGE WITHOUT NOTICE.

CAUTION: DIGITAL TRANSISTOR

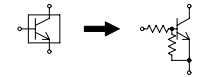

PCB010 VM8135

SYSTEM CONTROL/SERVO SCHEMATIC DIAGRAM

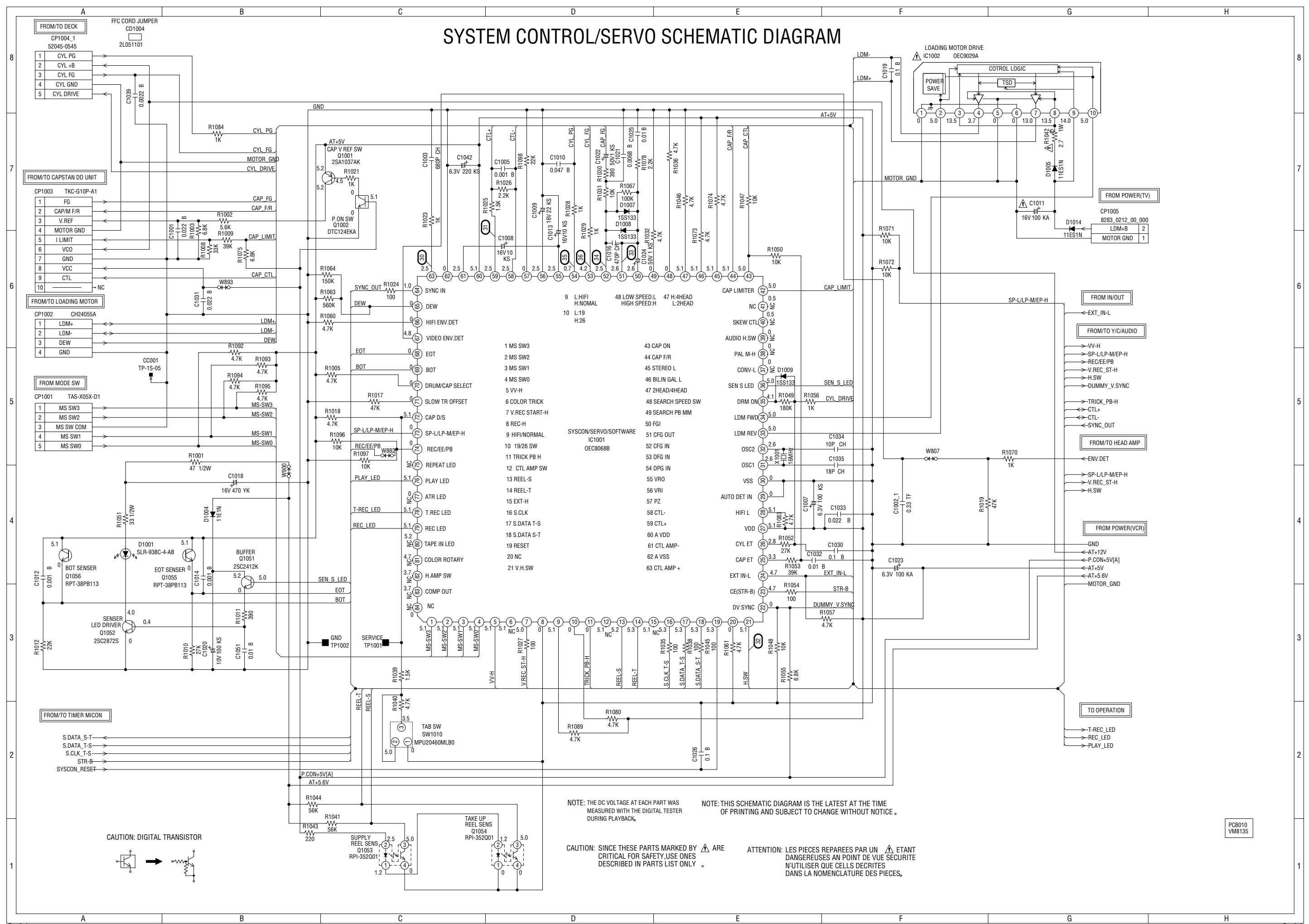

NOTE: THE DC VOLTAGE AT EACH PART WAS MEASURED WITH THE DIGITAL TESTER DURING PLAYBACK.

NOTE: THIS SCHEMATIC DIAGRAM IS THE LATEST AT THE TIME OF PRINTING AND SUBJECT TO CHANGE WITHOUT NOTICE.

CAUTION: SINCE THESE PARTS MARKED BY ARE CRITICAL FOR SAFETY, USE ONES DESCRIBED IN PARTS LIST ONLY.

ATTENTION: LES PIECES REPARÉES PAR UN ÉTANT DANGEREUSES AN POINT DE VUE SECURITE N'UTILISER QUE CELLS DECRITES DANS LA NOMENCLATURE DES PIECES.

CAUTION: DIGITAL TRANSISTOR

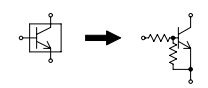

PCB010 VM8135

POWER(VCR) SCHEMATIC DIAGRAM

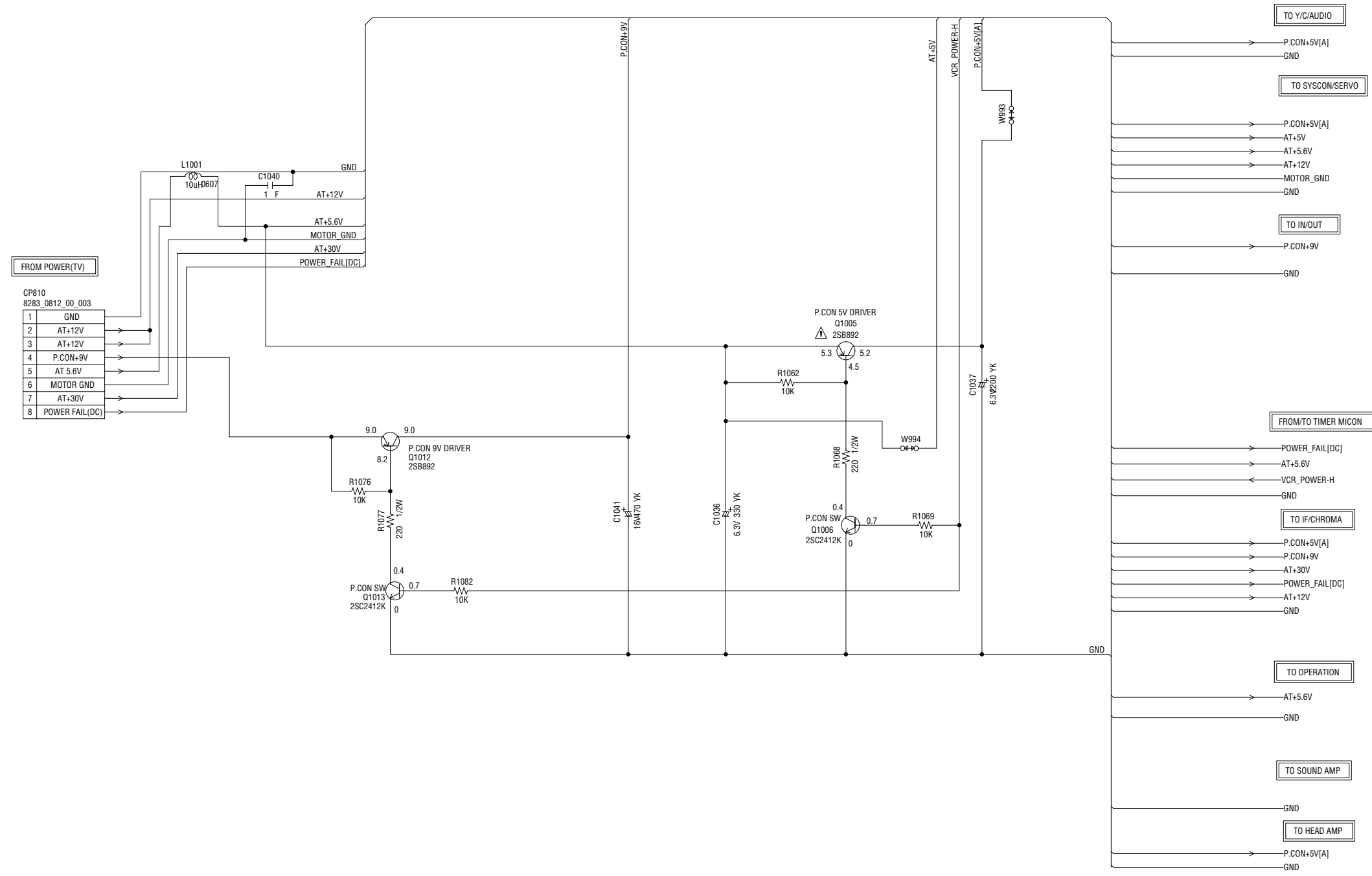

CP810
8283_0812_00_003

1	GND
2	AT+12V
3	AT+12V
4	P.CON+9V
5	AT 5.6V
6	MOTOR GND
7	AT+30V
8	POWER FAIL(DC)

NOTE: THE DC VOLTAGE AT EACH PART WAS MEASURED WITH THE DIGITAL TESTER DURING PLAYBACK.

NOTE: THIS SCHEMATIC DIAGRAM IS THE LATEST AT THE TIME OF PRINTING AND SUBJECT TO CHANGE WITHOUT NOTICE.

PC8010
VM8135

OPERATION(1) SCHEMATIC DIAGRAM

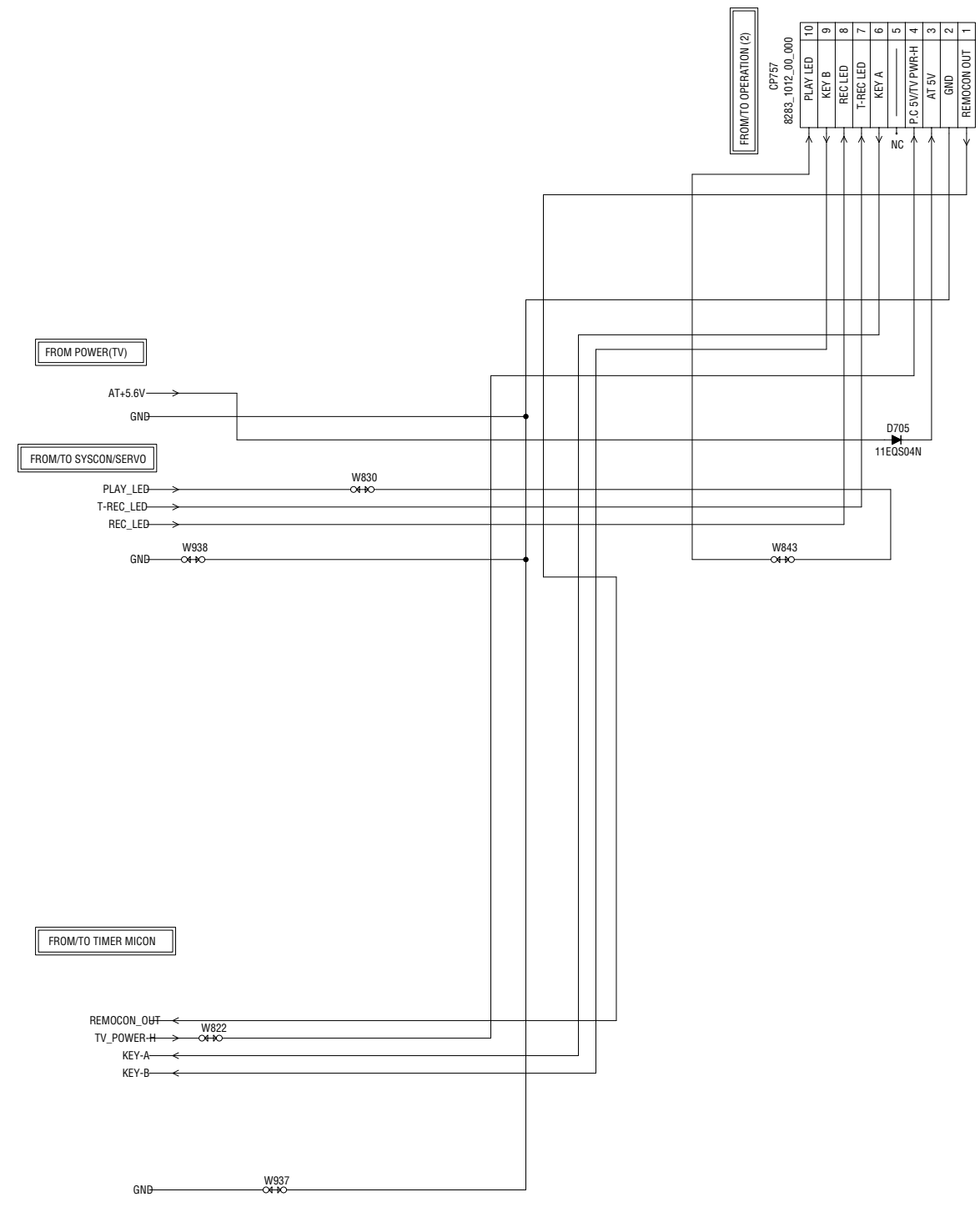

NOTE: THIS SCHEMATIC DIAGRAM IS THE LATEST AT THE TIME OF PRINTING AND SUBJECT TO CHANGE WITHOUT NOTICE.

PCB010
VM8135

INTERCONNECTION DIAGRAM

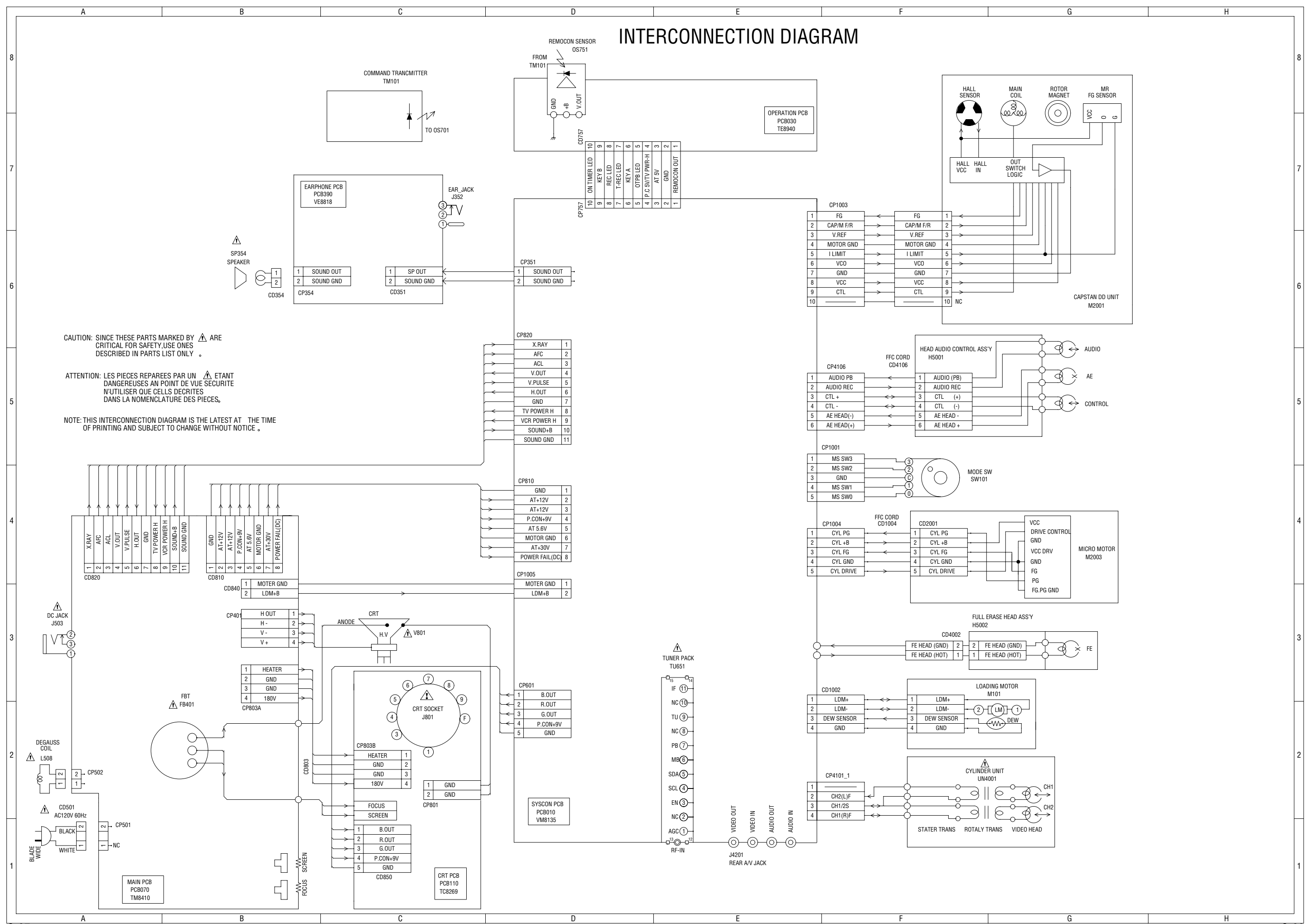

CAUTION: SINCE THESE PARTS MARKED BY ARE CRITICAL FOR SAFETY, USE ONES DESCRIBED IN PARTS LIST ONLY.

ATTENTION: LES PIECES REPARÉES PAR UN ÉTANT DANGEREUSES AU POINT DE VUE SÉCURITÉ, N'UTILISER QUE CELLES DÉCRITES DANS LA NOMENCLATURE DES PIÈCES.

NOTE: THIS INTERCONNECTION DIAGRAM IS THE LATEST AT THE TIME OF PRINTING AND SUBJECT TO CHANGE WITHOUT NOTICE.

WAVEFORMS

DEFLECTION

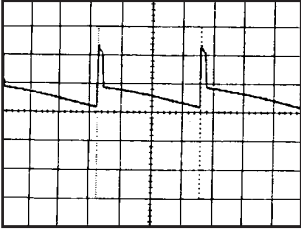

① 20V 5ms/div

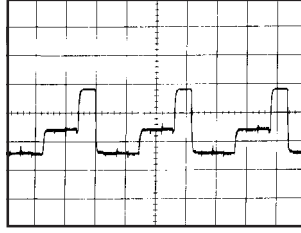

⑥ 50V 20 μ s/div

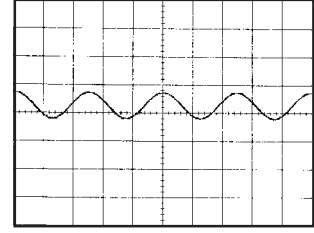

⑪ 1V 1ms/div

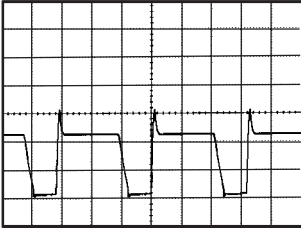

② 5V 20 μ s/div

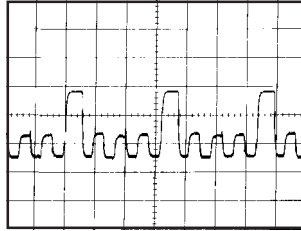

⑦ 50V 20 μ s/div

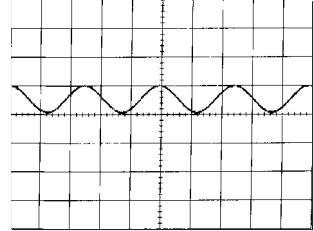

⑫ 1V 1ms/div

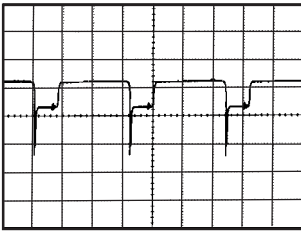

③ 5V 20 μ s/div

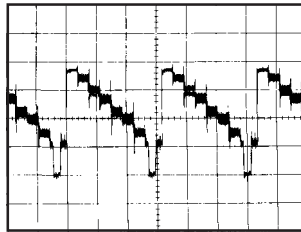

⑧ 200mV 20 μ s/div

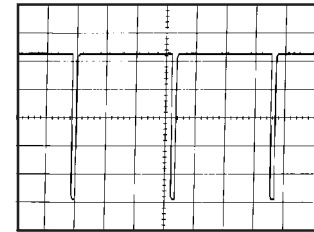

⑬ 1V 5ms/div

IF/CHROMA

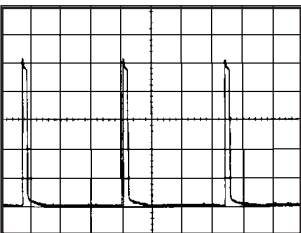

④ 5V 5ms/div

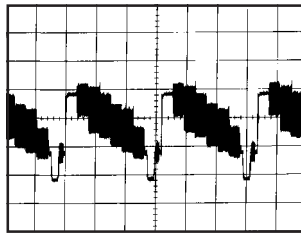

⑨ 500mV 20 μ s/div

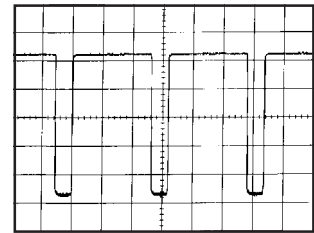

⑭ 1V 20 μ s/div

CRT

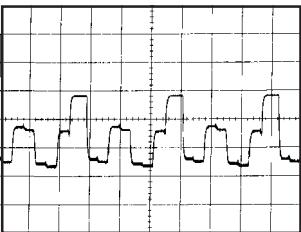

⑤ 50V 20 μ s/div

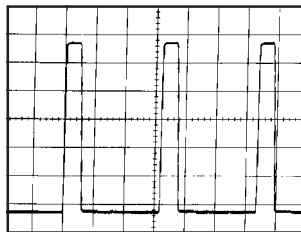

⑩ 2V 20 μ s/div

SOUND AMP

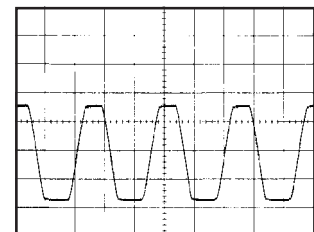

⑮ 5V 1ms/div

NOTE: The following waveforms were measured at the point of the corresponding balloon number in the schematic diagram.

WAVEFORMS

Y/C/AUDIO

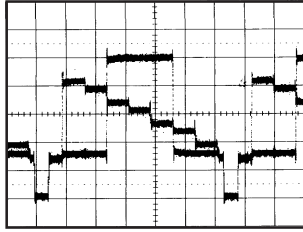

①⑥ REC
0.5V P-P

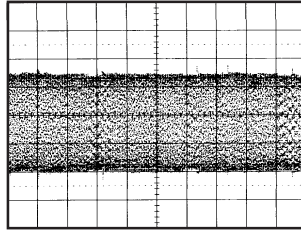

②① REC
0.34V P-P

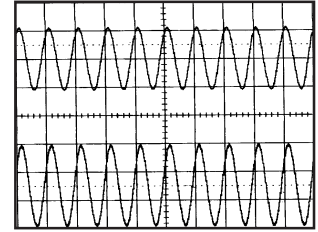

②⑥ REC/PB
0.5V 1ms/div

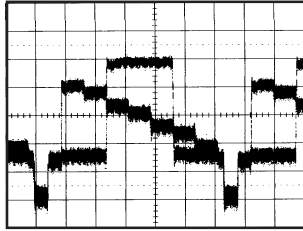

①⑦ PB
0.51V P-P

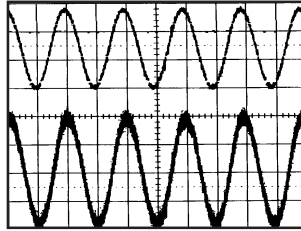

②② PB
20mV 5ms/div

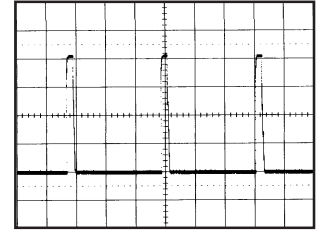

②⑦ REC/PB
0.4V P-P

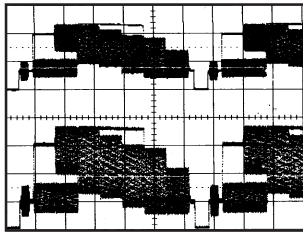

①⑧ REC
0.5V P-P

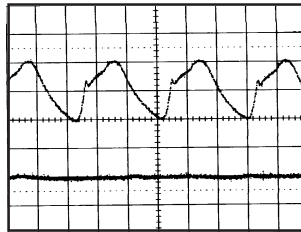

②③ REC
500mV 5 μ s/div

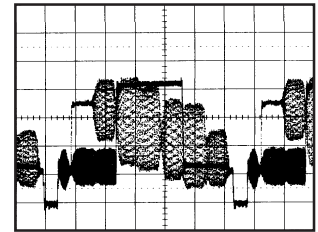

②⑧ PB
2.06V P-P

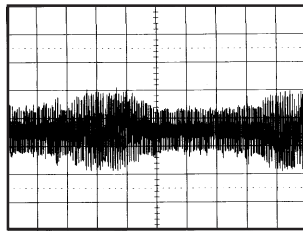

①⑨ PB
100mV 20 μ s/div

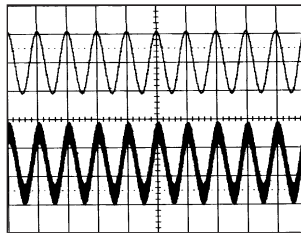

②④ REC
1V 1ms/div

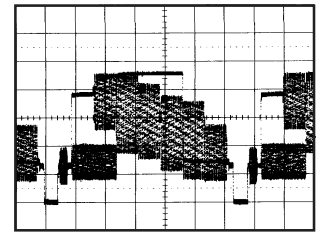

②⑨ REC/PB
0.96V P-P

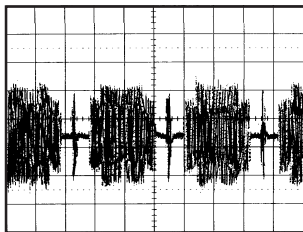

②⑩ REC
0.3V P-P

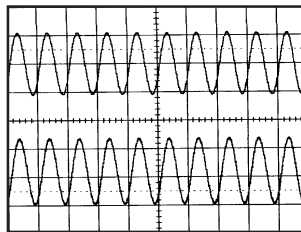

②⑤ REC
1V 1ms/div

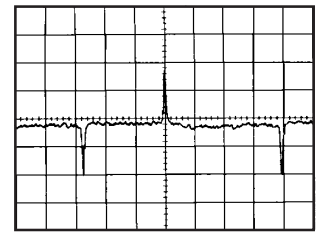

③⑩ REC/PB
0.5V 5ms/div

SYSCON/SERVO

NOTE: The following waveforms were measured at the point of the corresponding balloon number in the schematic diagram.

WAVEFORMS

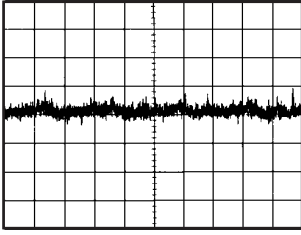

③① REC/PB
20mV 5ms/div

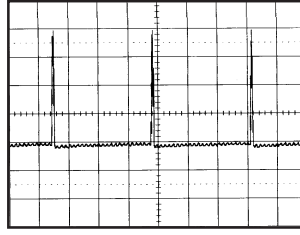

③⑤ REC/PB
1V 10ms/div

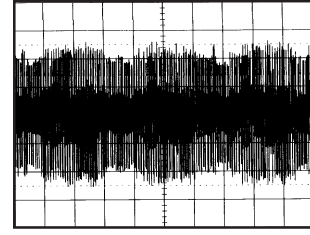

④⑩ PB
100mV 20 μ s/div

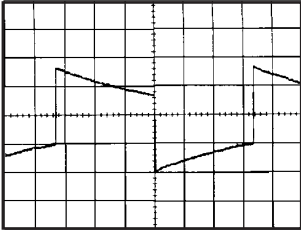

③② REC/PB
2V 5ms/div

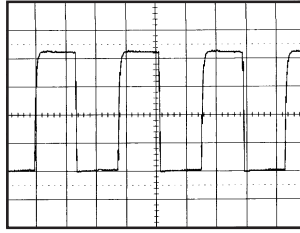

③⑥ REC/PB
1V 0.5ms/div

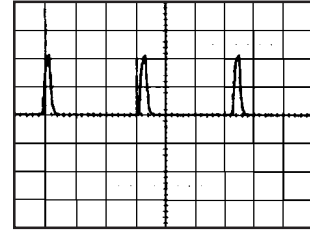

④① REC
1V 20 μ s/div

IN/OUT

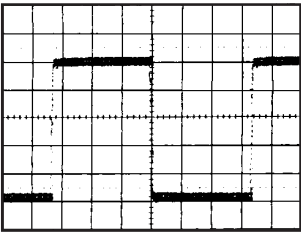

③② REC/PB
0.5V 5ms/div

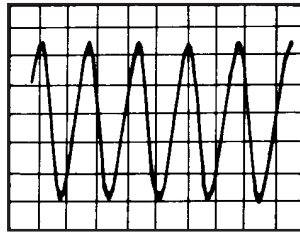

③⑦ REC/PB
1.2V P-P

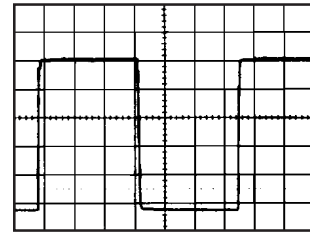

④② REC
500mV 5ms/div

HEAD AMP

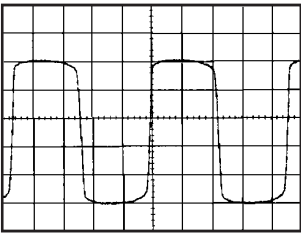

③③ REC/PB
0.5V 0.2ms/div

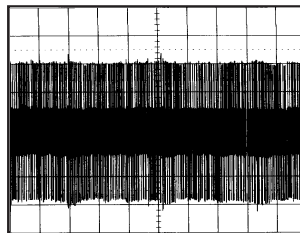

③⑧ REC
50mV 20 μ s/div

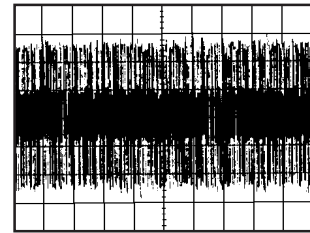

④③ REC
50mV 50ms/div

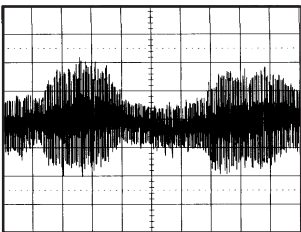

③④ REC/PB
20mV 0.5ms/div

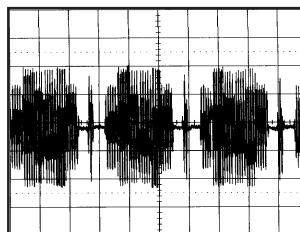

③⑨ REC
100mV 20 μ s/div

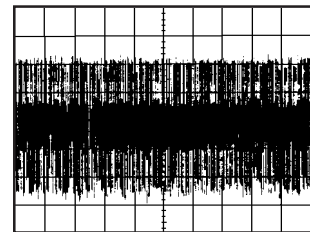

④④ REC
50mV 0.1s/div

NOTE: The following waveforms were measured at the point of the corresponding balloon number in the schematic diagram.

WAVEFORMS

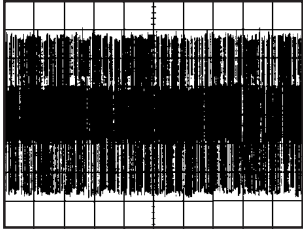

④⑤ REC
500mV 50ms/div

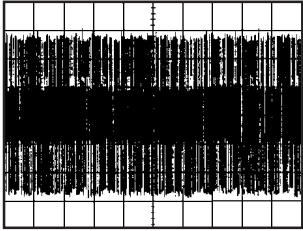

④⑥ REC
500mV 50ms/div

NOTE: The following waveforms were measured at the point of the corresponding balloon number in the schematic diagram.

MECHANICAL EXPLODED VIEW

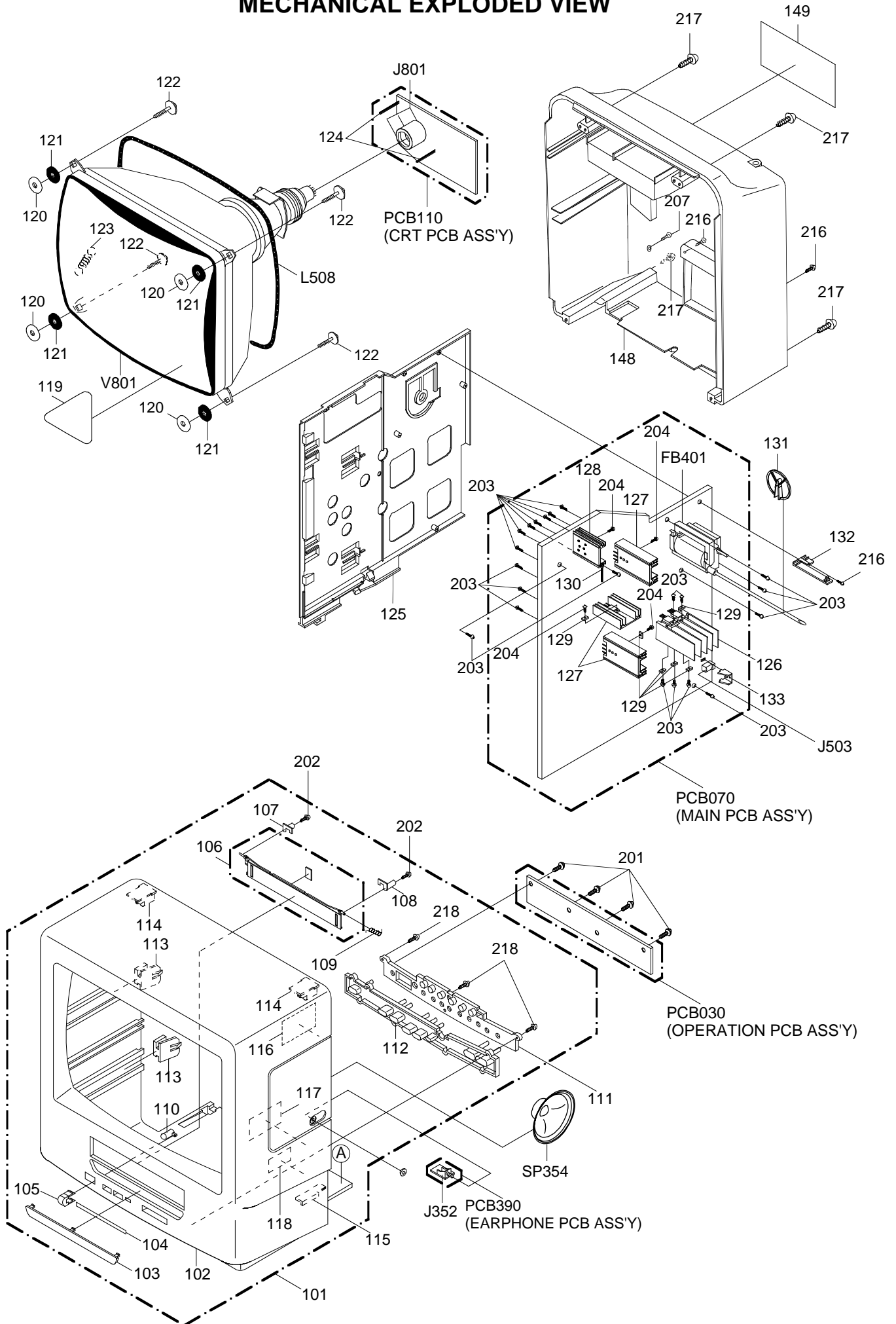

MECHANICAL EXPLODED VIEW

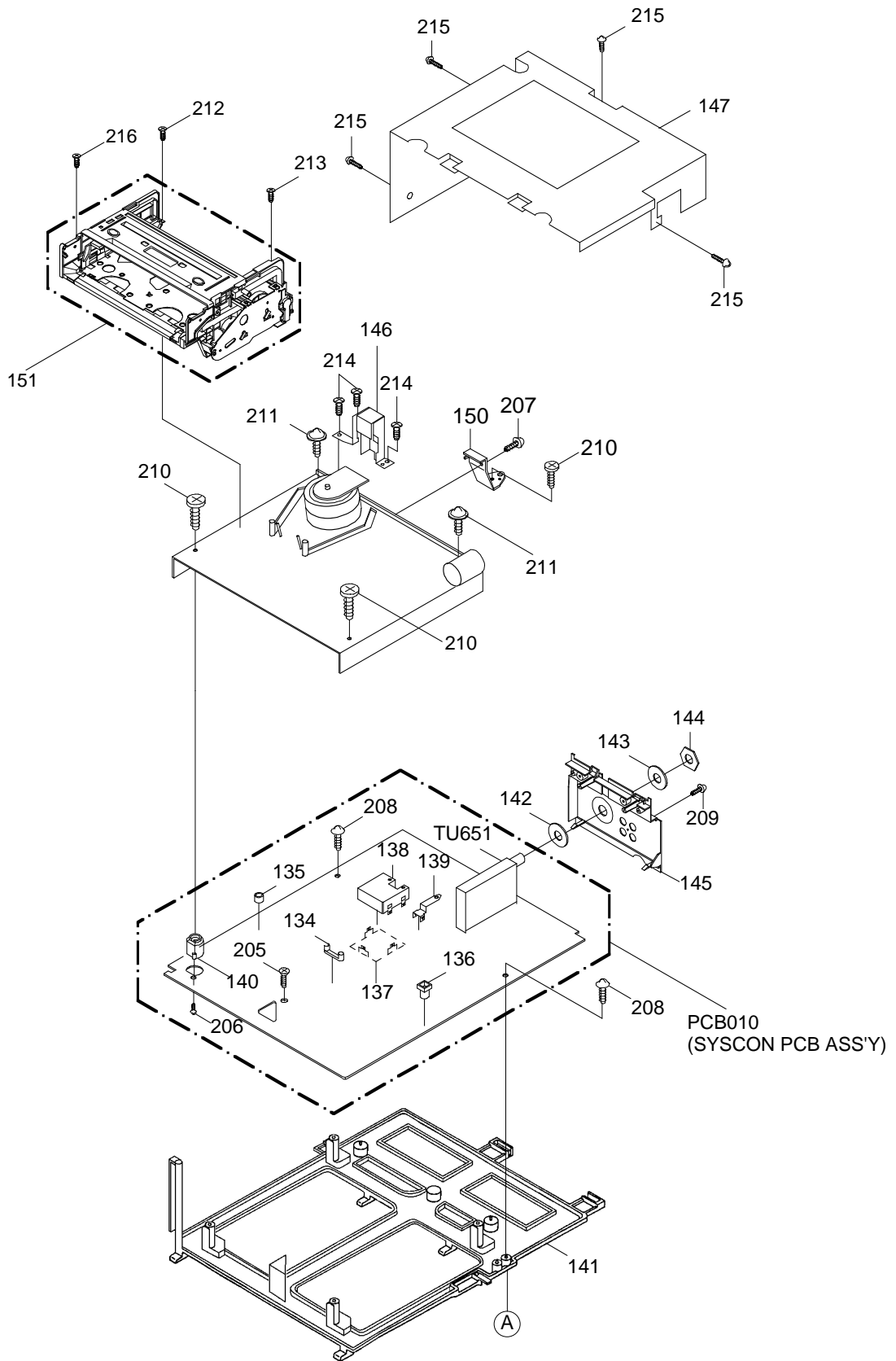

CHASSIS EXPLODED VIEW (TOP VIEW)

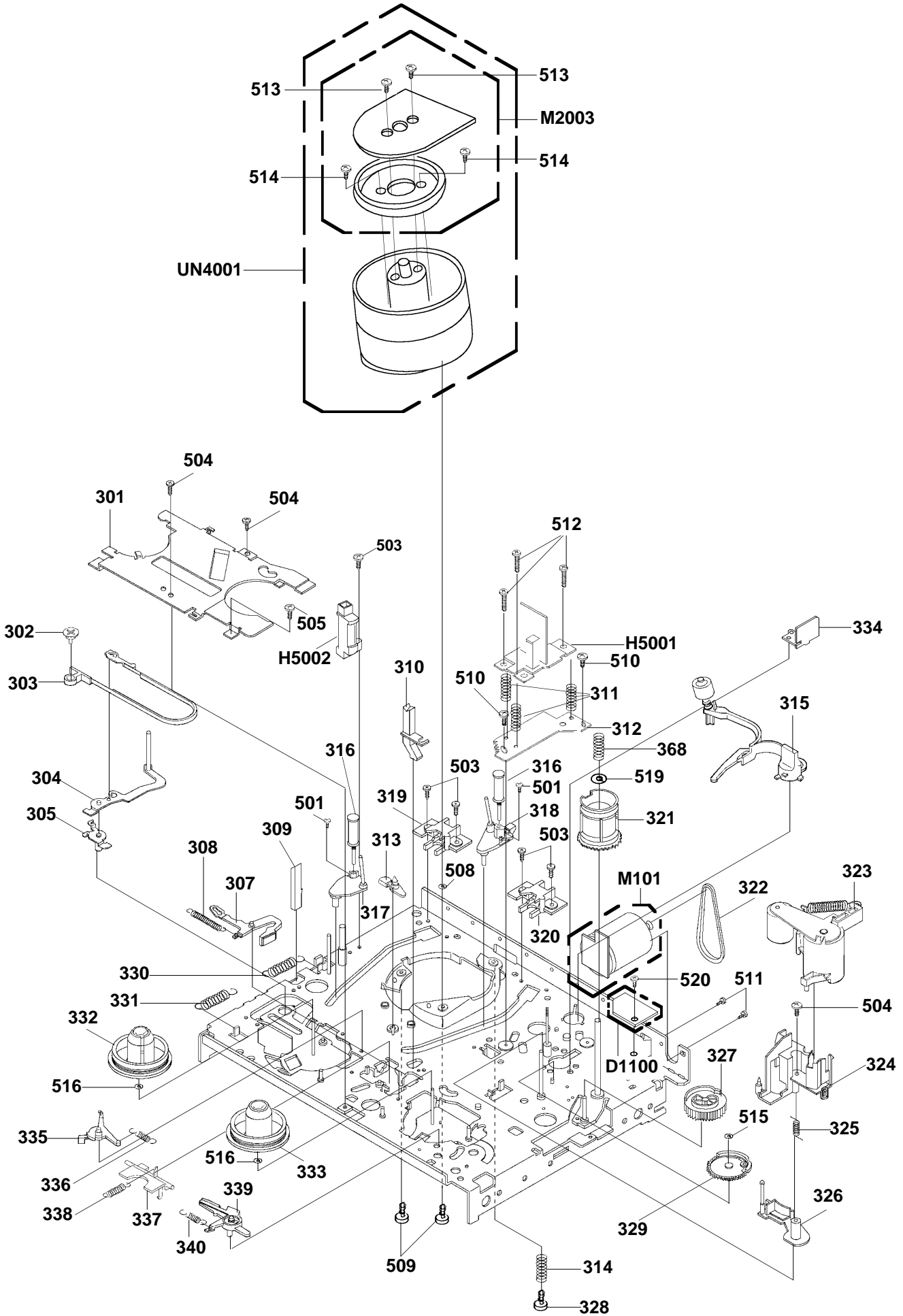

CHASSIS EXPLODED VIEW (BOTTOM VIEW)

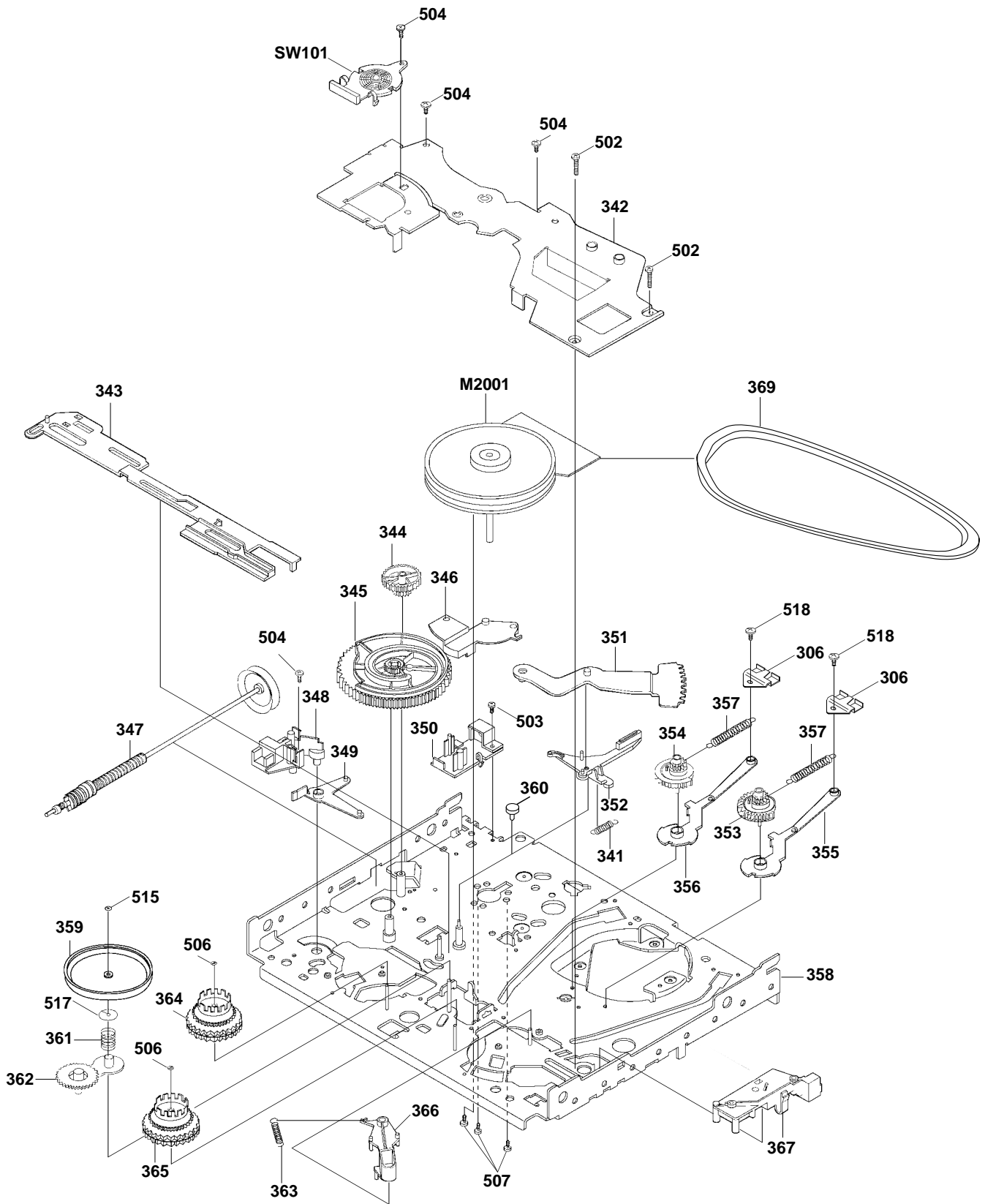

FRONT LOADING UNIT 15 EXPLODED VIEW

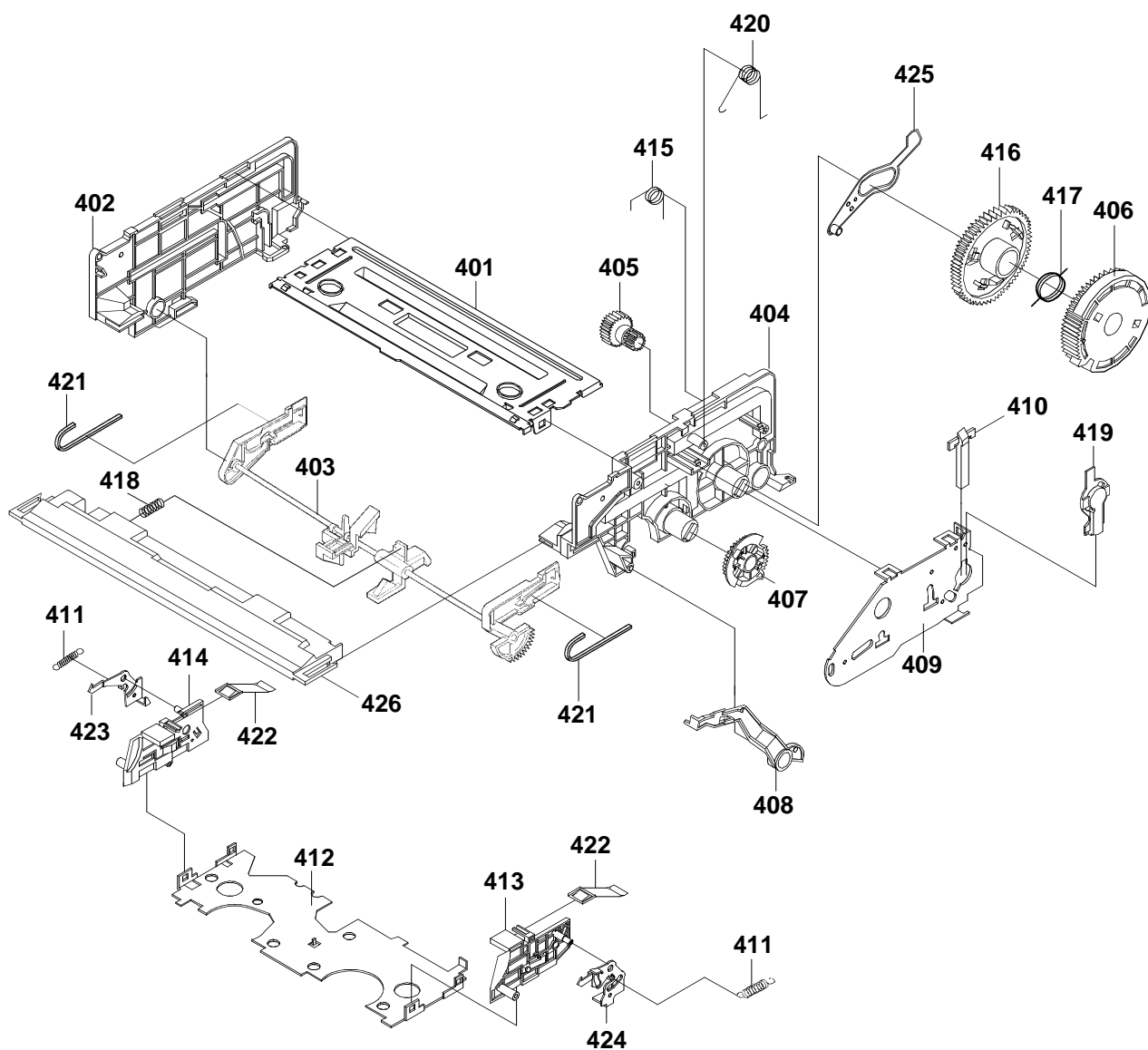

MECHANICAL REPLACEMENT PARTS LIST

REF. NO.	PART NO.	DESCRIPTION	REF. NO.	PART NO.	DESCRIPTION		
101	A51286P720	CABINET,FRONT ASS'Y	140	85OP000441	SPACER,P.C.B.		
102	701WPJA537	CABINET,FRONT	141	761WPA0091	HOLDER,DECK		
103	711WPDA199	PLATE,FRONT	142	800WR00024	SHEET,CRT SUPPORT		
104	7230005780	SHEET,LED	143	82A97A4077	WASHER	9.7x14xT0.7	
105	711WPA0063	PLATE,REMOCON	144	8300495207	NUT		
106	712WPJA357	FLAP	145	771WPA0211	PLATE,JACK		
	800WF00039	CUSHION	146	752WSA0113	SHIELD,CASE		
107	756WPA0042	HOLDER,FLAP (L)	147	752WSA0123	PLATE,DECK SHIELD		
108	756WPA0044	HOLDER,FLAP (R)	148	702WPA0464	CABINET,BACK		
109	743WKA0032	SPRING,FLAP	149	722A08A023	SHEET,RATING		
110	713WPA0049	GUIDE,REMOCON	150	761WSA0030	ANGLE,DECK BACK		
111	735WPA0335	BUTTON,BASE	151	85OA900207	FRONT LOADING UNIT 15		
112	735WPB0008	BUTTON,FRAME					
113	761WPA0027	HOLDER,PCB (2)	201	8110630A04	SCREW,TAP TITE (P)	BRAZIER 3x10	
114	---	CABINET HOLDER	202	8117B26804	SCREW,TAPPING (B0)	WH6 2.6x8	
115	709WPA0019	HOLDER,CABI SEIZE	203	8109630802	SCREW,TAP TITE (B)	BRAZIER 3x8	
116	726000A011	SHEET,CRT SERVICEMAN	204	810A130A04	SCREW/WASHER (A)	M3x10	
117	7220001059	SHEET,CSA WARNING	205	8117340A24	SCREW,TAPPING (B0)	FLAT 4x12	
118	7220001107	SHEET,HWC	206	8117330A04	SCREW,TAPPING (B0)	FLAT 3x10	
119	7230006603	FILM,DECORATION	207	8107230602	SCREW,TAP TITE (S)	BIND 3x6	
			208	8117540B04	SCREW,TAPPING (B0)	TRUSS 4x20	
120	769WSA0002	WASHER	209	8110230A02	SCREW,TAP TITE (P)	BIND 3x10	9.1x22xT1
121	800WR0A003	SHEET,CRT SUPPORT					
122	8111J50D04	SCREW,TAPPING (A)	210	8117140A24	SCREW,TAPPING (B0)	PAN 4x12	GW22 5x40
123	741WUA0001	SPRING,EARTH	211	8117D30A04	SCREW,TAPPING (B0)	WH8 BRAZIER 3x10	
124	---	COATING CLIP	212	8107226604	SCREW,TAP TITE (S)	BIND 2.6x6	
125	761WPA0148	HOLDER,TV PCB	213	8107126805	SCREW,TAP TITE (S)	PAN 2.6x8	
126	---	HEAT SINK	214	8107630504	SCREW,TAP TITE (S)	BRAZIER 3x5	
127	---	HEAT SINK	215	8107630604	SCREW,TAP TITE (S)	BRAZIER 3x6	
128	---	HEAT SINK	216	8110630A24	SCREW,TAP TITE (P)	BRAZIER 3x12	
129	---	METAL SPACER	217	8117540A64	SCREW,TAPPING (B0)	TRUSS 4x16	
			218	8110630804	SCREW,TAP TITE (P)	BRAZIER 3x8	
130	8995034000	CORD CLIP UL CO.					
131	759WPA0005	HOLDER,ANODE WIRE	---	JA5K0100	POLY BAG		
132	761WPA0118	HOLDER,CRT WIRE	---	J5128601	INSTRUCTION BOOK		
133	762WSA0031	BRACKET,DC JACK	---	791WHAA016	LAMIFILM BAG		
134	85OP700031	HOLDER,LED	---	792WHA0134	PACKAGE,TOP		
135	754WPAA003	COVER,LED (L)	---	792WHA0135	PACKAGE,BOTTOM		
136	754WPAA004	COVER,LED (R)	---	793WCDA479	GIFT BOX		
137	753WSA0057	SHIELD,AUDIO					
138	752WSA0112	SHIELD,HEAD AMP					
139	753WSA0058	PLATE,EARTH SYSCON					

CHASSIS/FRONT LOADING UNIT 15 REPLACEMENT PARTS LIST

REF. NO.	PART NO.	DESCRIPTION	REF. NO.	PART NO.	DESCRIPTION		
# 301	85OP600531	BRACKET,BRAKE(VP)	401	85OP900700	BRACKET,TOP(2)		
302	85OP400358	ADJUST,TENSION	402	85OP900675	BRACKET,SIDE L		
303	85OA400122	TENSION BAND ASS'Y	403	85OA900210	LINK ASS'Y 3		
304	85OA400124	TENSION ARM ASS'Y	404	85OP900615	BRACKET,SIDE R		
305	85OA400123	TENSION LEVER 2 ASS'Y	405	85OP900601	GEAR,JOINT		
306	85OP300169	SLIDER,LOADING 2	406	85OP900602	GEAR,CAM		
# 307	85OA600178	MAIN BRAKE T(VP)ASS'Y	407	85OP900609	GEAR,LINK R		
# 308	85OP800308	SPRING,MAIN BRAKE (VP)	408	85OP900672	LEVER,FLAP 2		
309	85OP900564	REFLECTOR,EOT	409	85OP900616	BRACKET,SIDE R2		
310	85OP400434	REFLECTOR,LED 2	410	85OP900621	REFLECTOR,BOT		
311	85OP800315	SPRING,AC HEAD 2	411	85OP800296	SPRING,LOCKER		
312	85OP500060	BASE,AC HEAD	412	85OP900611	CASS,HOLDER		
313	85OP000394	POST,CASS GUIDE L	413	85OP900613	CASS,SIDE R		
314	85OP800245	SPRING,AZIMUTH 2	414	85OP900668	CASS,SIDE L		
# 315	85OA500013	AHC ASS'Y	415	85OP800298	SPRING,BRACKET R		
316	85OA400102	GUIDE ROLLER ASS'Y	416	85OP900608	GEAR,CLUTCH		
317	85OA400179	BASE,S INCLINED 2 ASS'Y	417	85OP800297	SPRING,CLUTCH		
318	85OA400180	BASE,T INCLINED 2 ASS'Y	418	85OP800317	SPRING,LEVER REC(2)		
319	85OP400330	CATCHER,S	419	85OP900620	COVER,SENSOR BOT		
320	85OP400332	CATCHER,T	420	85OP800290	SPRING,EARTH		
# 321	85OP400430	CAM,PINCH ROLLER (PB)	421	85OP800294	SPRING,LINK		
322	85OP600487	BELT,LOADING	422	85OP800299	SPRING,PACK		
# 323	85OA400157	PINCH ROLLER (PB) BLOCK	423	85OP900605	LOCKER,L		
324	85OP900541	CASS,OPENER	424	85OP900606	LOCKER,R		
325	85OP800264	SPRING,P5	425	85OP900610	LEVER,BOT		
# 326	85OA400168	P5 ARM ASS'Y(PB)	426	85OP900677	TAPE,GUIDE PIECE(2)		
327	85OP400342	CAM,GEAR					
328	8146230A14	JOINT SCREW BIND	M3x11	501	8110217401	SCREW,TAP TITE(P) BIND	1.7x4.0
# 329	85OP400450	CAM,P5		502	8109226A64	SCREW,TAP TITE(B) BIND	2.6x16
				503	8107226804	SCREW,TAP TITE(S) BIND	2.6x8
330	85OP400356	SPRING,TENSION ARM 2		504	8107226604	SCREW,TAP TITE(S) BIND	2.6x6
# 331	85OP400357	SPRING,TENSION ARM 1		505	8107123604	SCREW,TAP TITE(S) PAN	2.3x6
332	85OP200216	REEL S		506	82P166005N	POLYSLIDER WASHER(CUT)	1.6x6.0xT0.5
333	85OP200217	REEL T		507	8109126804	SCREW,TAP TITE(B)PAN	2.6x8
# 334	85OP400446	CATCHER,P5 (VP)		508	82Q3154B3N	POLYSLIDER WASHER	3.1x5.4xT0.13
335	85OP600465	SUB BRAKE S		509	810A130604	SCREW/WASHER(A)	M3x6
336	85OP800253	SPRING,S-S BRAKE		510	810B126604	SCREW/WASHER(B)	M2.6x6.0
337	85OP200247	ARM,JOINT		511	8102130304	SCREW,PAN	M3.0x3.0
338	85OP800262	SPRING,JOINT ARM		512	8102126A04	SCREW,PAN	M2.6x10
339	85OA600157	SUB BRAKE T ASS'Y		513	810A123504	SEMS A	M2.3x5.0
340	85OP800254	SPRING,T-S BRAKE		514	85OPAA0197	SCREW,MOTOR	M3x5
341	85OP800255	SPRING,CAP BRAKE		515	82P266005N	POLYSLIDER WASHER(CUT)	2.6x6.0xT0.5
342	85OP600485	PLATE,BOTTOM		516	82Q264713N	POLYSLIDER WASHER	2.6x4.7xT0.13
# 343	85OP600527	ROD, MAIN(VP)		517	82P26A005N	POLYSLIDER WASHER(CUT)	2.6x10xT0.5
344	85OP400341	GEAR,MIDDLE		518	8149117805	SCREW,TAP-TITE(P)	1.7x8 P3
# 345	85OP600529	CAM,MAIN(VP)		519	82Q4070C5N	POLYSLIDER WASHER	4.1x7.0xT0.25
# 346	85OP600530	LEVER,MAIN BRAKE (VP)					
# 347	85OA600179	WORM (VP)ASS'Y		520	8107226404	SCREW,TAP TITE(S) BIND	2.6x4
348	85OP600483	BRACKET,WORM F					
349	85OP600526	LEVER,RATCHET		D1100	DAK0000160	DEW SENSOR(W/AL,PLATE)	HDP-05-24
350	85OP600484	BRACKET,WORM R		H5001	1523D91032	HEAD (AUDIO CONTROL)	HVMXA1031A
351	85OA300058	LOADING LEVER ASS'Y		H5002	1543D02010	HEAD,FULL ERASE	HVFHF0059A
352	85OA600174	CAPSTAN BRAKE ASS'Y (M.J)					
353	85OP300152	GEAR,LOADING S		M101	85OA600180	LOADING MTR.(D)ASS'Y	
354	85OP300153	GEAR,LOADING T		M2001	1594J98005	CAPSTAN DD UNIT	SP39BE
355	85OA300053	LOADING ARM S ASS'Y		M2003	1589V11004	MICRO MOTOR	EP14BA
356	85OA300054	LOADING ARM T ASS'Y					
357	85OP800263	SPRING,LOADING GEAR		# SW101	0520244007	MODE SWITCH	SRZZ0B091K
# 358	85OA000231	MAIN CHASSIS ASS'Y		△ UN4001	A51904B500	CYLINDER UNIT ASS'Y	A51904B500
359	85OP200213	CENTER,PULLEY					
360	85OP000443	SPACER,CAPSTAN					
361	85OP800261	SPRING,C-PULLEY					
# 362	85OA200067	ARM IDLER (VP) ASS'Y					
363	85OP800270	SPRING,LEVER TENSION					
# 364	85OA200069	CLUTCH GEAR T (VP) ASS'Y					
# 365	85OA200068	CLUTCH GEAR S (VP) ASS'Y					
366	85OP400360	LEVER,TENSION					
# 367	85OP400359	HOLDER,TENSION					
368	85OP800310	SPRING,CAM PINCH					
369	85OP200215	BELT,CAPSTAN					

Note: Some parts labeled # are not compatible, but they are very similar before servicing, be sure to check the parts in the INFORMATION FOR USING THE DECK PARTS (OVD-5) for the repair. Because if you use wrong parts, the deck or tape will be damaged.

ELECTRICAL REPLACEMENT PARTS LIST

REF. NO.	PART NO.	DESCRIPTION	REF. NO.	PART NO.	DESCRIPTION
RESISTORS			DIODES		
△ R361	R0L2U2010J	RC 1 OHM 1/2W	D355	D1VT001330	DIODE, SILICON 1SS133T-77
△ R362	R0L2U2010J	RC 1 OHM 1/2W	△ D404	D28A0KF400	DIODE, SILICON F10KF40
△ R407	R3K181102J	R, METAL 1K OHM 1W	△ D405	D28T10ELS6	DIODE, RECTIFIER 10ELS6TA1B2
△ R408	R3U20B5R6J	R, METAL OXIDE 5.6 OHM 3W	D406	D28T11E1N1	DIODE, SILICON 11E1N-TA1B2
△ R409	R3K20B5R6J	R, METAL 5.6 OHM 3W	△ D407	D94TA12B12	DIODE, ZENER HZ12B2L TD
△ R412	R425T4472F	R, METAL 4.7K OHM 1/4W	△ D409	D28T10ELS6	DIODE, RECTIFIER 10ELS6TA1B2
△ R413	R425T4683F	R, METAL 68K OHM 1/4W	△ D410	D28T10ELS6	DIODE, RECTIFIER 10ELS6TA1B2
△ R467	R6148A5R6J	R, FUSE 5.6 OHM 2W	△ D411	D2B000RG20	DIODE, SILICON RG2
△ R471	R425T4183F	R, METAL 18K OHM 1/4W	△ D413	D28T10ELS6	DIODE, RECTIFIER 10ELS6TA1B2
△ R472	R425T4123F	R, METAL 12K OHM 1/4W	△ D418	D94TA11B13	DIODE, ZENER HZ11B3L TD
△ R474	R615U2100J	R, FUSE 10 OHM 1/2W	△ D501	D2BTRM11C0	DIODE, RECTIFIER RM11C
△ R476	R6358A4R7J	R, FUSE 4.7 OHM 2W	△ D502	D2BTRM11C0	DIODE, RECTIFIER RM11C
△ R480	R3U28B120J	R, METAL OXIDE 12 OHM 3W	△ D503	D2BTRM11C0	DIODE, RECTIFIER RM11C
△ R481	R3K20B120J	R, METAL 12 OHM 3W	△ D504	D2BTRM11C0	DIODE, RECTIFIER RM11C
△ R494	R3118A4R7J	R, METAL OXIDE 4.7 OHM 2W	D505	D25TGWJ420	DIODE, SCHOTTKY 2GWJ42
△ R500	R21202275K	R, SOLID 2.7M OHM 1/2W	D506	D25T1R5NU0	DIODE, SILICON 1R5NU41
△ R501	R5Y2CE2R2J	R, CEMENT 2.2 OHM 7W	D507	D28T10ELS6	DIODE, RECTIFIER 10ELS6TA1B2
△ R504	R0L2U2154J	RC 150K OHM 1/2W	△ D508	D2BT0EG01Z	DIODE, SILICON EG01Z-V0
△ R505	R3K28B333J	R, METAL 33K OHM 3W or	△ D509	D28A0KF200	DIODE, SILICON F10KF20B
	R3U28B333J	R, METAL OXIDE 33K OHM 3W	△ D510	D280F5KF20	DIODE, FAST RECOVERY F5KF20
△ R508	R3328D473J	R, METAL OXIDE 47K OHM 5W	D512	D28TQS04N0	DIODE, SCHOTTKY 11EQS04N-TA1B2
△ R511	R5Y2CF1R8J	R, CEMENT 1.8 OHM 10W	△ D513	D28T11E1N1	DIODE, SILICON 11E1N-TA1B2
△ R526	R61581100J	R, FUSE 10 OHM 1W	D514	D28T11E1N1	DIODE, SILICON 11E1N-TA1B2
△ R544	R0L2U2154J	RC 150K OHM 1/2W	D515	D1VT001330	DIODE, SILICON 1SS133T-77
△ R558	R635844R7J	R, FUSE 4.7 OHM 1/4W	D516	D1VT001330	DIODE, SILICON 1SS133T-77
	R561	R3U18A220J R, METAL OXIDE 22 OHM 2W	D517	D28T11E1N1	DIODE, SILICON 11E1N-TA1B2
△ R598	R63584220J	R, FUSE 22 OHM 1/4W	D518	D28T11E1N1	DIODE, SILICON 11E1N-TA1B2
△ R688	R3X1818R2J	R, METAL 8.2 OHM 1W	D519	D1VT024720	DIODE, SILICON 1S2472T-77
△ R802	R3U18A153J	R, METAL 15K OHM 2W	D520	D28T21DQN4	DIODE, SCHOTTKY 21DQ04N-TA2B1
△ R805	R3U18A153J	R, METAL 15K OHM 2W	D522	D97U01601B	DIODE, ZENER MTZJ16B T-77
△ R810	R3U18A153J	R, METAL 15K OHM 2W	△ D525	D28T11E1N1	DIODE, SILICON 11E1N-TA1B2
△ R1042	R655812R7J	R, FUSE 2.7 OHM 1W	D526	D1VT024720	DIODE, SILICON 1S2472T-77
CAPACITORS			ICs		
△ C354	E02LF3102M	CE 1000 UF 25V	D527	D28T11ESN1	DIODE, SILICON 11ES1N-TA1B2
△ C403	E53ZF3102M	CE 1000 UF 25V VZ	D530	D1VT001330	DIODE, SILICON 1SS133T-77
C404	E53ZF4102M	CE 1000 UF 35V VZ	△ D531	D2BT0EG01Z	DIODE, SILICON EG01Z-V0
C406	P1S300222J	CP 0.0022 UF 50V	△ D532	D2BT0EG01Z	DIODE, SILICON EG01Z-V0
△ C415	E02LF3102M	CE 1000 UF 25V	D601	D1VT001330	DIODE, SILICON 1SS133T-77
△ C420	E53ZF4102M	CE 1000 UF 35V VZ	D602	D97U07R51B	DIODE, ZENER MTZJ7.5B T-77
△ C435	P3N1F5123J	CPP 0.012 UF 630V	D603	D97U01201B	DIODE, ZENER MTZJ12B T-77
△ C438	C01BBP7H3K	CC 0.0022 UF 2KV BP	D604	D28T11ESN1	DIODE, SILICON 11ES1N-TA1B2
△ C439	P3N1F5563J	CPP 0.056 UF 630V	D606	D97U01201B	DIODE, ZENER MTZJ12B T-77
△ C449	E53ZT2331M	CE 330 UF 16V VZ	D607	D28TELS2N2	DIODE, RECTIFIER 10ELS2N-TA1B2
△ C470	E51ZT6220M	CE 22 UF 63V	D608	D28TELS2N2	DIODE, RECTIFIER 10ELS2N-TA1B2
△ C471	E53ZT54R7M	CE 4.7 UF 50V VZ	D610	DD3RLFB01L	DIODE, SILICON LFB-01L
△ C472	E53FF56R8K	CE 6.8 UF 50V NP	D611	DD3RLFB01L	DIODE, SILICON LFB-01L
△ C474	E0ELFD470M	CE 47 UF 250V	D612	DD3RLFB01L	DIODE, SILICON LFB-01L
△ C475	E53Z02222M	CE 2200 UF 16V VZ	D613	D1VT001330	DIODE, SILICON 1SS133T-77
C502	C13HB07H3K	CC 0.0022 UF 2KV B	D705	D28TQS04N0	DIODE, SCHOTTKY 11EQS04N-TA1B2
C503	C13HB07H3K	CC 0.0022 UF 2KV B	D753	002132Q040	LED SLZ-936C-11-S-T1
△ C506	P2222B224K	CMP 0.22 UF 250V AC	D754	002132Q040	LED SLZ-936C-11-S-T1
△ C507	E51CGC471M	CE 470 UF 200V	D756	002132Q040	LED SLZ-936C-11-S-T1
△ C508	E632T1471D	CE 470 UF 10V	D757	002132Q040	LED SLZ-936C-11-S-T1
△ C515	E02LTB010M	CE 1 UF 160V	D801	D1VT001330	DIODE, SILICON 1SS133T-77
△ C519	E53YF3222M	CE 2200 UF 25V	D802	D1VT001330	DIODE, SILICON 1SS133T-77
△ C520	E53YF3472M	CE 4700 UF 25V	D1001	0001300030	LED SLR-938C-4-AB
△ C521	E03F04221M	CE 220 UF 35V	D1004	D28T11E1N1	DIODE, SILICON 11E1N-TA1B2
△ C522	E142T36R8M	CE 6.8 UF 25V	D1005	D28T11ESN1	DIODE, SILICON 11ES1N-TA1B2
△ C528	E53ZF2102M	CE 1000 UF 16V VZ	D1007	D1VT001330	DIODE, SILICON 1SS133T-77
△ C531	C034E0J13M	CC 0.001 UF 125V MX	D1008	D1VT001330	DIODE, SILICON 1SS133T-77
C532	P21503685K	CMP 6.8 UF 250V	D1009	D1VT001330	DIODE, SILICON 1SS133T-77
△ C533	C034F0JL3M	CC 0.0033 UF 125V MX	D1014	D28T11ESN1	DIODE, SILICON 11ES1N-TA1B2
△ C542	E02LT2470M	CE 47 UF 16V	D4001	D1VTB721Q0	DIODE, SCHOTTKY RB721QT-77
C547	C01BBP7W2K	CC 820 PF 2KV BP	D4002	DD3RLFB01L	DIODE, SILICON LFB-01L
C550	P21503475K	CMP 4.7 UF 250V	D4006	DD3RLFB01L	DIODE, SILICON LFB-01L
C551	P3N1F5103J	CPP 0.01 UF 630V	D4007	D1VT001330	DIODE, SILICON 1SS133T-77
C642	E02LT2102M	CE 1000 UF 16V	D4206	D97U01301B	DIODE, ZENER MTZJ13B T-77
△ C1011	E50HU2101M	CE 100 UF 16 V	ICs		
D102	D1VT001330	DIODE, SILICON 1SS133T-77	△ IC101	I53D03033B	IC OEC3033B
D111	D28T11E1N1	DIODE, SILICON 11E1N-TA1B2	IC102	I53D001BN6	IC M24C01-BN6
D112	D28T11E1N1	DIODE, SILICON 11E1N-TA1B2	IC103	I9UJ0T600H	IC PST600H
D116	D1VT001330	DIODE, SILICON 1SS133T-77	△ IC401	I03SD78400	IC LA7840
D117	D97U06R81B	DIODE, ZENER MTZJ6.8B T-77	△ IC501	I0ED046050	IC TDA4605-3
D121	D97U06R81B	DIODE, ZENER MTZJ6.8B T-77	△ IC502	I07S061610	IC BA6161N
D352	D1VT001330	DIODE, SILICON 1SS133T-77	△ IC503	I0BK9050S0	IC SI-8050S LF1101
D354	D1VT001330	DIODE, SILICON 1SS133T-77	△ IC504	I0GA99RF10	IC PQ09RF1
			△ IC505	I07D003580	IC BA10358 or
				I0QK978120	IC NJM7812FA

ELECTRICAL REPLACEMENT PARTS LIST

REF. NO.	PART NO.	DESCRIPTION	REF. NO.	PART NO.	DESCRIPTION
ICS			TRANSISTORS		
△ IC506	I1KA978120	IC KIA7812PI	Q4207	T8YJ2412K0	TRANSISTOR, SILICON 2SC2412KT146(R,S)
△ IC601	I03DE76170	IC LA76170	Q4212	T6YJ1037K0	TRANSISTOR, SILICON 2SA1037AKT146(R,S)
IC1001	I51K08068B	IC OEC8068B	COILS & TRANSFORMERS		
△ IC1002	I07S09029A	IC OEC9029A	L001	02A6A8A0A1	CORE, FERRITE HF57T18.5*10*10
IC4001	I03F371022	IC LA71022M	L101	02167B4R7G	COIL 4.7 UH
IC4101	I03FG70001	IC LA70001M-TRM	L402	021614102K	COIL 1 MH
TRANSISTORS			L404	022100028A	COIL, LINEARITY ELH5L6113 or
Q100	T8YJ2412K0	TRANSISTOR, SILICON 2SC2412KT146(R,S)	L501	021W67331K	COIL, LINEARITY 2G-27
Q101	T8YJ2412K0	TRANSISTOR, SILICON 2SC2412KT146(R,S)	△ L502	029A000002	COIL, LINE FILTER 330 UH
Q102	T8YJ2412K0	TRANSISTOR, SILICON 2SC2412KT146(R,S)	△ L503	029X000065	COIL, LINE FILTER FK0B160MH14
Q104	T8YJ2412K0	TRANSISTOR, SILICON 2SC2412KT146(R,S)	L504	021207100M	COIL SU16V-20030
Q105	T8YJ2412K0	TRANSISTOR, SILICON 2SC2412KT146(R,S)	L505	021805330L	COIL 10 UH
Q106	T8YJ2412K0	TRANSISTOR, SILICON 2SC2412KT146(R,S)	L506	021805330L	COIL 33 UH
Q107	T8YJ2412K0	TRANSISTOR, SILICON 2SC2412KT146(R,S)	△ L508	028R140024	COIL, DEGAUSS 8R140024
Q109	T6YJ1037K0	TRANSISTOR, SILICON 2SA1037AKT146(R,S)	L509	021W24222K	COIL 2.2 MH
Q351	T8YJ2412K0	TRANSISTOR, SILICON 2SC2412KT146(R,S)	L601	03361A011S	COIL, VIDEO IFT 361A011
Q352	T8YJ2412K0	TRANSISTOR, SILICON 2SC2412KT146(R,S)	L603	0336020378	COIL, VIDEO IFT 3602037
△ Q354	TC5T018154	TRANSISTOR, SILICON 2SC1815Y(TPE2)	L605	021LA6180K	COIL 18 UH
△ Q355	TDWT00400E	TRANSISTOR, SILICON 2SD400E	L606	021LA6150K	COIL 15 UH
△ Q356	TBWT00544E	TRANSISTOR, SILICON 2SB544E	L607	021LA61R5K	COIL 1.5 UH
Q357	TB3T008920	TRANSISTOR, SILICON 2SB892(S,T)-AE	L608	021LA6150K	COIL 15 UH
Q358	TNYJJ05001	COMPOUND TRANSISTOR DTC114TKAT146	L609	021LA6680K	COIL 68 UH
△ Q401	TD30018250	TRANSISTOR, SILICON 2SD1825Z	L613	021LA6560K	COIL 56 UH
△ Q402	TC304424M0	TRANSISTOR, SILICON 2SC4424(M,N)	L614	021673101K	COIL 100 UH
△ Q500	T25FK26620	TRANSISTOR, FIELD EFFECT 2SK2662	L615	021LA6560K	COIL 56 UH
Q501	TPYTB03001	COMPOUND TRANSISTOR DTA114ESTP	L1001	02167D100K	COIL 10 UH
△ Q502	TF6FR2AM80	THYRISTOR CR2AM-8-F8	L4001	021LA6151K	COIL 150 UH
△ Q503	TB30008270	TRANSISTOR, SILICON 2SB827R,S	L4002	021LA6221K	COIL 220 UH
Q504	TDWT011110	TRANSISTOR, SILICON 2SD1111-AA	L4003	02167D101K	COIL 100 UH
Q505	TCYT1740S0	TRANSISTOR, SILICON 2SC1740SP(R,S) TP	L4004	021LA6680K	COIL 68 UH
Q506	TCYT1740S0	TRANSISTOR, SILICON 2SC1740SP(R,S) TP	L4005	031626007S	COIL, BIAS OSC 1626007
Q507	TAYT0933S0	TRANSISTOR, SILICON DTC114ESTP	L4006	02167D101K	COIL 100 UH
Q508	TNYTB03001	COMPOUND TRANSISTOR DTC114ESTP	L4007	02167D102K	COIL 1 MH
△ Q509	TDWT011110	TRANSISTOR, SILICON 2SD1111-AA	L4008	02167D101K	COIL 100 UH
Q510	TCST02001L	TRANSISTOR, SILICON 2SC2001(C)-T_L	L4010	021LA6101K	COIL 100 UH
Q512	TCST02001L	TRANSISTOR, SILICON 2SC2001(C)-T_L	L4011	021LA6271K	COIL 270 UH
Q514	TNYTB03001	COMPOUND TRANSISTOR DTC114ESTP	L4012	021LA6680K	COIL 68 UH
Q515	TNYTB03001	COMPOUND TRANSISTOR DTC114ESTP	L4101	021LA6220K	COIL 22 UH
△ Q516	TB3T008920	TRANSISTOR, SILICON 2SB892(S,T)-AE	L4102	021673101K	COIL 100 UH
Q517	TCST009450	TRANSISTOR, SILICON 2SC945(C)-T(P,Q)	L4205	021673101K	COIL 100 UH
Q604	T8YA2412K0	TRANSISTOR, SILICON 2SC2412KT147(R,S)	T401	0450190101	TRANS, HORIZONTAL DRIVE 5019010
Q606	T8YJ2412K0	TRANSISTOR, SILICON 2SC2412KT146(R,S)	△ T501	048140044W	TRANSFORMER, SWITCHING 8140044W
Q607	T8YJ2412K0	TRANSISTOR, SILICON 2SC2412KT146(R,S)	JACKS		
Q609	T8YA2412K0	TRANSISTOR, SILICON 2SC2412KT147(R,S)	J352	060C121010	EARPHONE, JACK 3.5 TC38-001-05-T
Q613	T8YA2412K0	TRANSISTOR, SILICON 2SC2412KT147(R,S)	△ J503	0602602001	JACK, DC HEC0470-01-630
Q616	TCYT1740S0	TRANSISTOR, SILICON 2SC1740SP(R,S) TP	△ J801	066X120014	SOCKET, CRT HPS3200-010501
Q801	TAST007330	TRANSISTOR, SILICON 2SA733(C)-T(P,Q)	J4201	060M021002	JACK, PLATE T6551-ABCC
△ Q804	TC3F042170	TRANSISTOR, SILICON 2SC4217(D,E)-RAC	SWITCHES		
△ Q805	TC3F042170	TRANSISTOR, SILICON 2SC4217(D,E)-RAC	SW771	0504201T31	SWITCH, TACT SKHVBED010
△ Q806	TC3F042170	TRANSISTOR, SILICON 2SC4217(D,E)-RAC	SW772	0504201T31	SWITCH, TACT SKHVBED010
Q1001	T6YJ1037K0	TRANSISTOR, SILICON 2SA1037AKT146(R,S)	SW775	0504201T31	SWITCH, TACT SKHVBED010
Q1002	TNYJC05001	COMPOUND TRANSISTOR DTC124EKAT146	SW776	0504201T31	SWITCH, TACT SKHVBED010
△ Q1005	TB3T008920	TRANSISTOR, SILICON 2SB892(S,T)-AE	SW777	0504201T31	SWITCH, TACT SKHVBED010
Q1006	T8YJ2412K0	TRANSISTOR, SILICON 2SC2412KT146(R,S)	SW778	0504201T31	SWITCH, TACT SKHVBED010
Q1012	TB3T008920	TRANSISTOR, SILICON 2SB892(S,T)-AE	SW779	0504201T31	SWITCH, TACT SKHVBED010
Q1013	T8YJ2412K0	TRANSISTOR, SILICON 2SC2412KT146(R,S)	SW781	0504201T31	SWITCH, TACT SKHVBED010
Q1051	T8YJ2412K0	TRANSISTOR, SILICON 2SC2412KT146(R,S)	SW1010	0501W02005	PUSH SWITCH MPU20460MLB0
Q1052	TCYT2872S0	TRANSISTOR, SILICON 2SC2872S	VARIABLE RESISTOR		
Q1053	0002700530	PHOTO COUPLER RPI-352Q01	VR502	V116313BT6	VOLUME, SEMI FIXED EVNDXAA03B13
Q1054	0002700530	PHOTO COUPLER RPI-352Q01	P.C. BOARD ASSEMBLIES		
Q1055	0000700320	TRANSISTOR, PHOTO RPT-38PB113	PCB010	A51286P01A	PCB ASS'Y VM8135C
Q1056	0000700320	TRANSISTOR, PHOTO RPT-38PB113	PCB030	A51286P03A	PCB ASS'Y TE8940A
Q4001	T8YJ2412K0	TRANSISTOR, SILICON 2SC2412KT146(R,S)	PCB070	A51275P07A	PCB ASS'Y TM8410A
Q4003	TCWT022740	TRANSISTOR, SILICON 2SC2274(E,F)-AA	PCB110	A51275P11A	PCB ASS'Y TC8269A
Q4004	TCWT022740	TRANSISTOR, SILICON 2SC2274(E,F)-AA	PCB390	A51259B39A	PCB ASS'Y VE8818B
Q4007	TAWT0984K0	TRANSISTOR, SILICON 2SC2274(E,F)-AA	MISCELLANEOUS		
Q4008	T8YJ2412K0	TRANSISTOR, SILICON 2SC2412KT146(R,S)	△ ANT001	125C108027	ANTENNA, ROD T4-216BNK-BK
Q4009	T8YJ2412K0	TRANSISTOR, SILICON 2SC2412KT146(R,S)	B402	024AT03655	CORE, BEADS BL01RN1-A63T6
Q4010	TCKT013170	TRANSISTOR, SILICON 2SC1317(Q,R,S)-T	B501	024DT03581	CORE, BEADS LFP3A-M3R2TA
Q4011	TCWT022740	TRANSISTOR, SILICON 2SC2274(E,F)-AA	B502	024AT03655	CORE, BEADS BL01RN1-A63T6
Q4012	T6YJ1037K0	TRANSISTOR, SILICON 2SA1037AKT146(R,S)	B503	024AT03655	CORE, BEADS BL01RN1-A63T6
Q4013	T8YJ2412K0	TRANSISTOR, SILICON 2SC2412KT146(R,S)	B504	024AT03655	CORE, BEADS BL01RN1-A63T6
Q4014	T8YJ2412K0	TRANSISTOR, SILICON 2SC2412KT146(R,S)	B505	024AT03655	CORE, BEADS BL01RN1-A63T6
Q4022	T6YJ1037K0	TRANSISTOR, SILICON 2SA1037AKT146(R,S)	B506	024AT03655	CORE, BEADS BL01RN1-A63T6
Q4202	T8YJ2412K0	TRANSISTOR, SILICON 2SC2412KT146(R,S)	B507	024AT03655	CORE, BEADS BL01RN1-A63T6
Q4205	TNYJC05001	COMPOUND TRANSISTOR DTC124EKAT146	CD351	06CH12406A	CORD, CONNECTOR CH12406A or
Q4206	T8YJ2412K0	TRANSISTOR, SILICON 2SC2412KT146(R,S)			

ELECTRICAL REPLACEMENT PARTS LIST

REF. NO.	PART NO.	DESCRIPTION	
MISCELLANEOUS			
	CD351	068112406A	CORD, CONNECTOR 8112406A or
		068D12240A	CORD, CONNECTOR 8D12240A
△	CD501	120R614904	CORD, AC 120R614904
△	CD503	121B164101	CORD, CAR BATTERY SI-PC107-67
	CD757	06CH2A012A	CORD, CONNECTOR CH2A012A
	CD801	068M82025A	CORD, CONNECTOR 8M82025A
	CD803	122E042302	CORD, JUMPER 2E042302
	CD810	06CH28096A	CORD, CONNECTOR CH28096A
	CD820	06CH2B026A	CORD, CONNECTOR CH2B026A
	CD840	06CH22077A	CORD, CONNECTOR CH22077A
	CD850	06CH25080A	CORD, CONNECTOR CH25080A
	CF601	1012T4R509	FILTER, CERAMIC SF5H4.5MCB-TF21
	CF602	1011T4R517	FILTER, CERAMIC EFCT4R5MW5
	CF603	102E245R01	FILTER, SAW M1964M
	CF605	1002AR5002	CERAMIC OSCILLATOR CSB503F44
	CP351	0694120099	CONNECTOR PCB SIDE 171825-2
	CP354	0694120010	CONNECTOR PCB SIDE 2-171825-2
	CP401	069W340018	CONNECTOR PCB SIDE TS-80P-04-V1
	CP501	0694430100	CORD, UX CONNECTOR 2-173270-3
	CP502	069W420029	CONNECTOR PCB SIDE TV-50P-02-A1
	CP601	069E250129	CONNECTOR PCB SIDE 8283_0512_00_000
	CP757	069E2A0129	CONNECTOR PCB SIDE 8283_1012_00_000
	CP801	069W320018	CONNECTOR PCB SIDE TS-80P-02-V1
	CP807	069W010010	CONNECTOR PCB SIDE 005P-2100
	CP810	069E280124	CONNECTOR PCB SIDE 8283_0812_00_003
	CP820	069E2B0129	CONNECTOR PCB SIDE 8283_1112_00_000
	CP830	069E260129	CONNECTOR PCB SIDE 8283_0612_00_000
	CD1004	122L051101	CORD, JUMPER 2L051101
	CD4002	06CH22070A	CORD, CONNECTOR CH22070A
	CD4106	122L061101	CORD, JUMPER 2L061101
	CP1001	0697150310	CONNECTOR PCB SIDE TAS-X05X-D1
	CP1002	06CH24055A	CORD, CONNECTOR CH24055A
	CP1003	06972A0580	CONNECTOR PCB SIDE TKC-G10P-A1
	CP1004	069R750028	CONNECTOR PCB SIDE 52045-0545
	CP1005	069E220129	CONNECTOR PCB SIDE 8283_0212_00_000
	CP4101	0697740590	CONNECTOR PCB SIDE TOC-T04X-A1
	CP4106	069R760028	CONNECTOR PCB SIDE 52045-0645
	CP803A	067R104019	WIRE HOLDER 51052-0400
	CP803B	067R104019	WIRE HOLDER 51052-0400
	CUS011	800WF00004	CUSHION-A
	CUS012	800WF00004	CUSHION-A
	CUS013	800WF00004	CUSHION-A
	CUS014	800WF00019	CUSHION-C
	CUS015	800WF00019	CUSHION-C
	CUS016	800WF00019	CUSHION-C
	CUS017	800WF00019	CUSHION-C
	CUS018	800WF00019	CUSHION-C
	CUS019	800WF00019	CUSHION-C
	CUS021	800WF00004	CUSHION-A
	CUS022	800WF00019	CUSHION-C
△	F501	081PA04002	FUSE 237004
△	F502	081PA6R302	FUSE 23706.3
△	F503	081PA04002	FUSE 237004
△	FB401	043214026B	TRANSFORMER, FLYBACK 3214026
	FH501	06710T0006	HOLDER, FUSE EYF-52BC
	FH502	06710T0006	HOLDER, FUSE EYF-52BC
	FH503	06710T0006	HOLDER, FUSE EYF-52BC
	FH504	06710T0006	HOLDER, FUSE EYF-52BC
	FH505	06710T0006	HOLDER, FUSE EYF-52BC
	FH506	06710T0006	HOLDER, FUSE EYF-52BC
△	ICP501	083PC02002	MICRO FUSE 251002
△	ICP502	083PC07002	MICRO FUSE 251007
	MS501	1283200022	SILICON, SHEET TC-30CG-TO-3P
	OS751	0779014001	REMOTE RECEIVER GP1U281R
	PF4001	0326230038	COIL, TRAP 2623003
△	RY501	0560150106	RELAY AJZ32197
△	RY502	0560150106	RELAY AJZ32197
△	RY504	0560152102	RELAY AJE649
△	SP354	070W132002	SPEAKER P-300W
	TM101	076R0BH01A	TRANSMITTER R25-0578
△	TU651	0145K00049	TUNER, UHF-VHF TECC1070PG26A
△	V801	098R140490	COLOR PICTURE TUBE W/DY A34JFQ90X23(VW)
	X101	100C32R803	CRYSTAL DSVT-200 32.768KHz
	X102	1002T01205	CERAMIC OSCILLATOR 12.08MHz
	X601	100W357903	CRYSTAL HC-49/U 3.579545MHz
	X1001	100CA01603	CRYSTAL HC-49/U-S 16MHz
	X4001	100DA3R525	CRYSTAL AT-49 3.579545MHz

RESISTOR

RC..... CARBON RESISTOR

CAPACITORS

CC..... CERAMIC CAPACITOR
 CE..... ALUMI ELECTROLYTIC CAPACITOR
 CP..... POLYESTER CAPACITOR
 CPP..... POLYPROPYLENE CAPACITOR
 CPL..... PLASTIC CAPACITOR
 CMP..... METAL POLYESTER CAPACITOR
 CMPL..... METAL PLASTIC CAPACITOR
 CMPP..... METAL POLYPROPYLENE CAPACITOR

SPEC.NO.	M512-86P
O/R NO.	W935029